

2T-G ENGINE SERVICE

	Page
CUTAWAY VIEW	5-2
CYLINDER HEAD	5-4
TIMING CHAIN	5-38
CYLINDER BLOCK	
SEE TO CYLINDER BLOCK OF 2T-3T ENGINE SERVICE SECTION	

CUTAWAY VIEW

Fig. 5-1

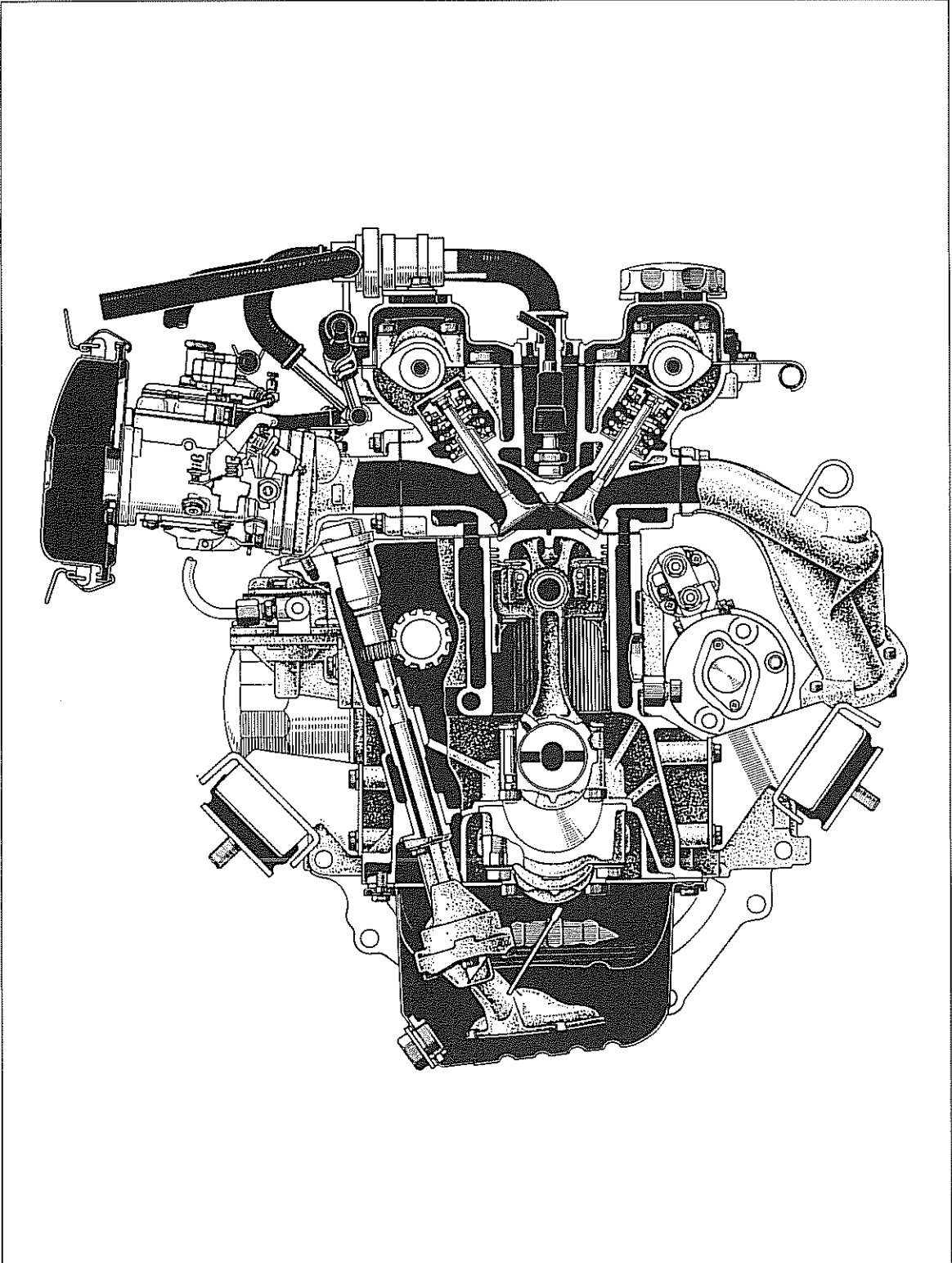
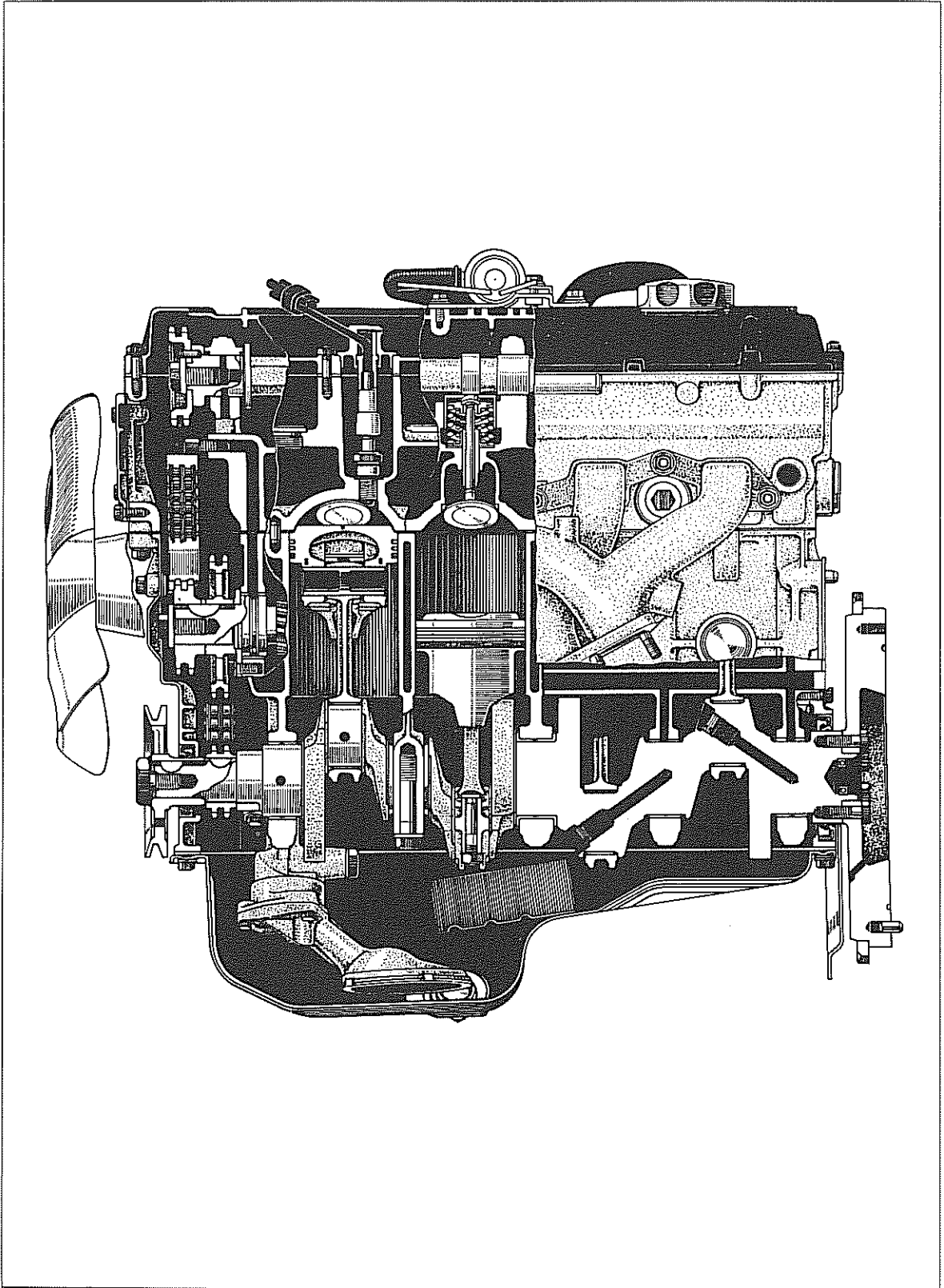

Fig. 5-2



CYLINDER HEAD

DISASSEMBLY

Disassemble the parts in the numerical order shown in the figure.

Fig. 5-3

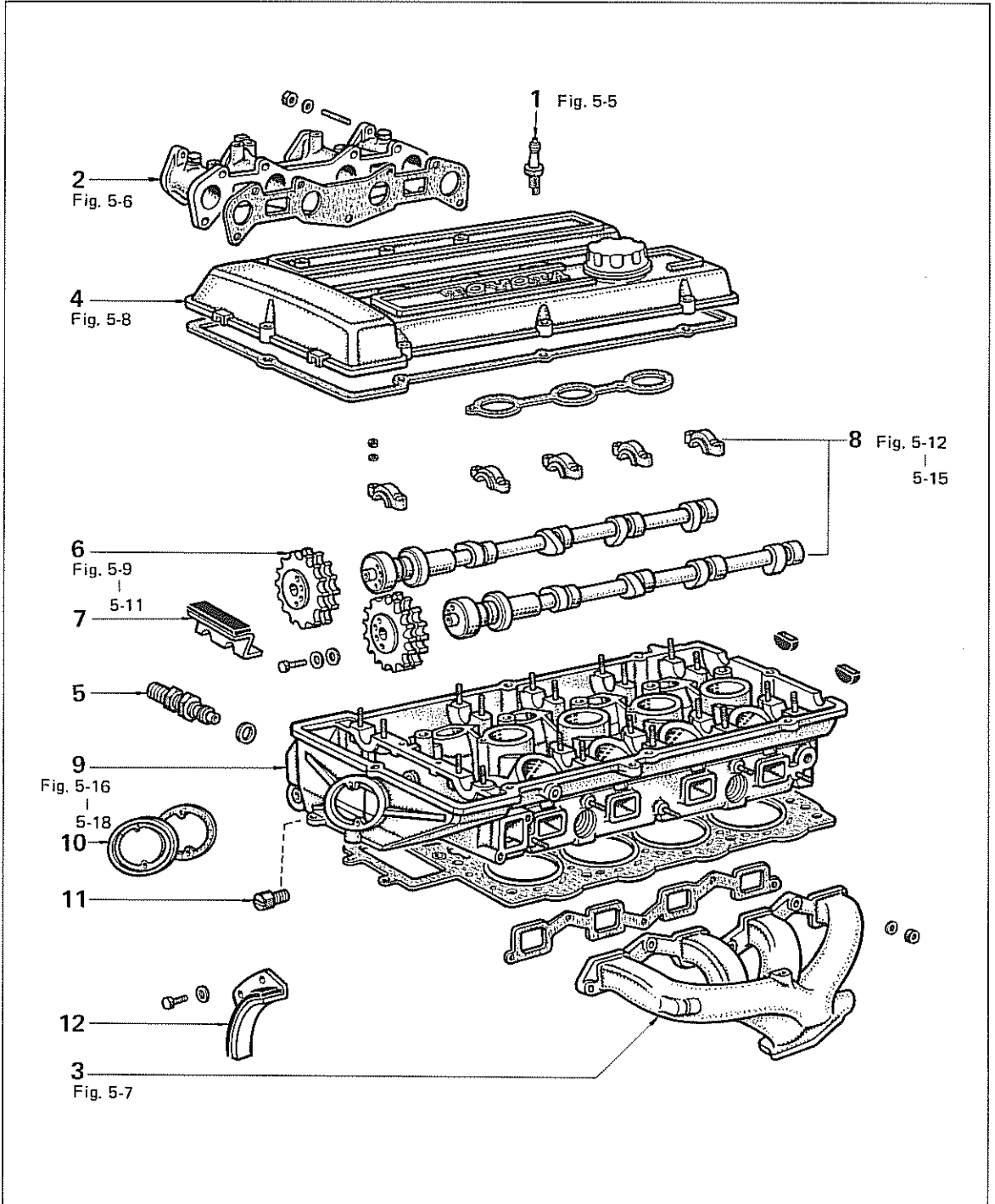
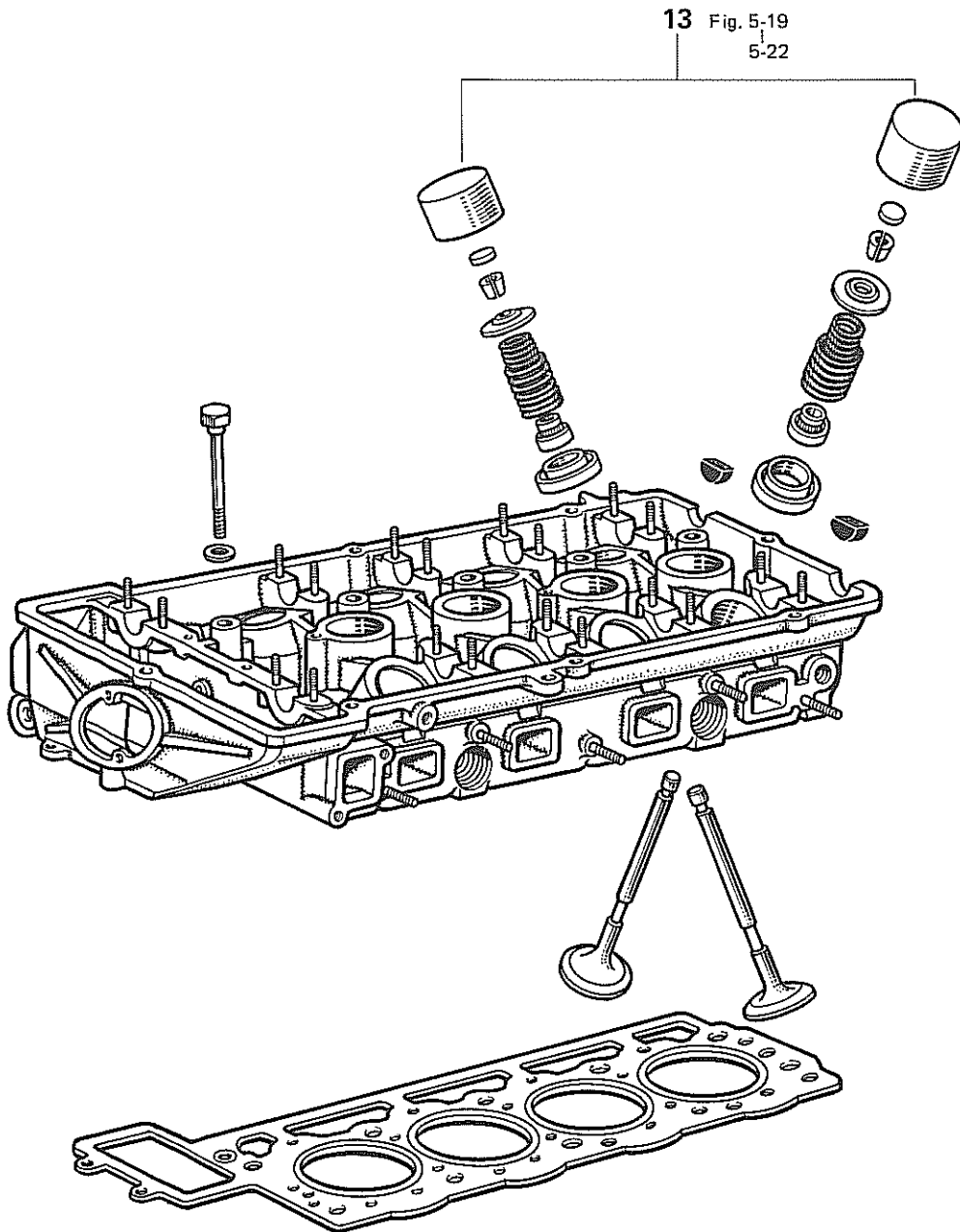
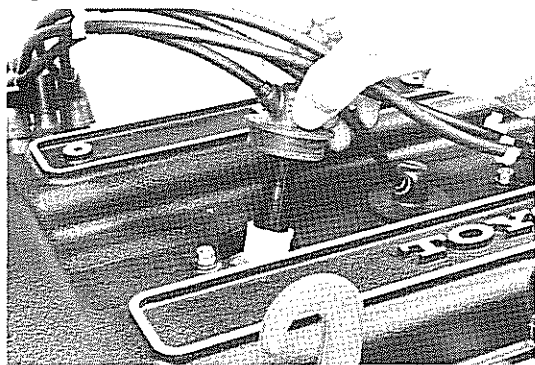

Fig. 5-4



- | | |
|---------------------------------|---------------------------|
| 1. Spark Plug | 8. Camshaft & Bearing Cap |
| 2. Intake Manifold | 9. Cylinder Head |
| 3. Exhaust Manifold | 10. Front Cover |
| 4. Cylinder Head Cover & Gasket | 11. Oil Nozzle |
| 5. No.2 Chain Tensioner | 12. No.3 Vibration Damper |
| 6. Camshaft Timing Gear | 13. Valve & Spring |
| 7. No.2 Vibration Damper | |

Fig. 5-5



Remove the plug cords by carefully pulling on the rubber boots.

Fig. 5-6

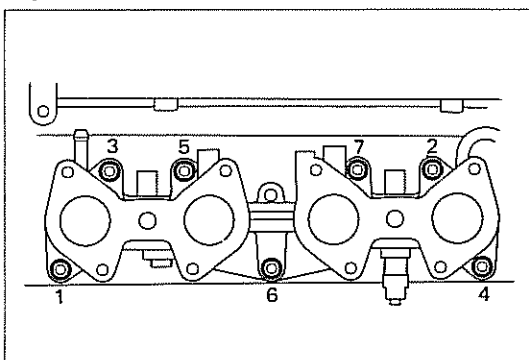

Loosen the intake manifold nut a little at a time and in the sequence shown in the figure.

Fig. 5-7

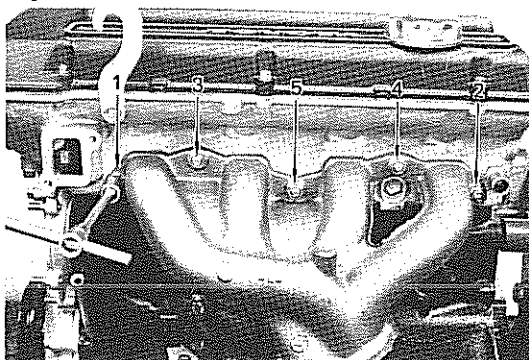

Loosen the exhaust manifold nut a little at a time and in the sequence shown in the figure.

Fig. 5-8

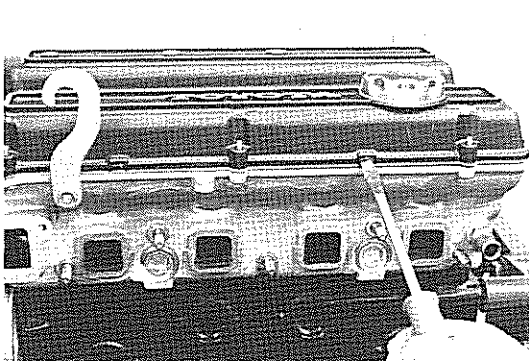

If the cylinder head cover is difficult to lift off, pry with a screwdriver between the head cover and head as shown in the figure.

Fig. 5-9

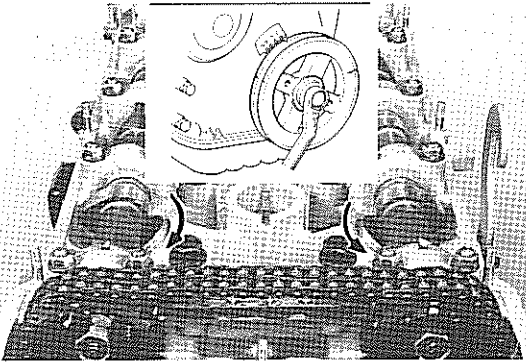

Set the No.1 cylinder to TDC/compression. At this time, the intake and exhaust valve lifters on No.1 cylinder should be rotate.

Fig. 5-10

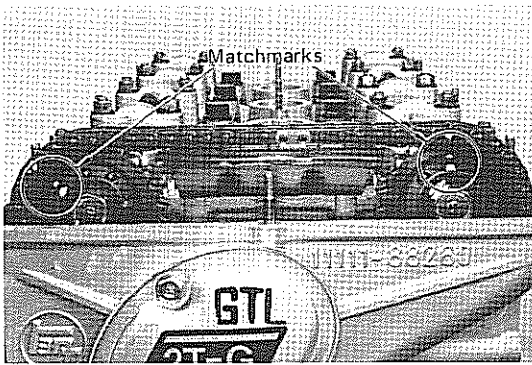

Place the matchmarks between the gears, chain and the pin holes for correct reassembly.

Fig. 5-11

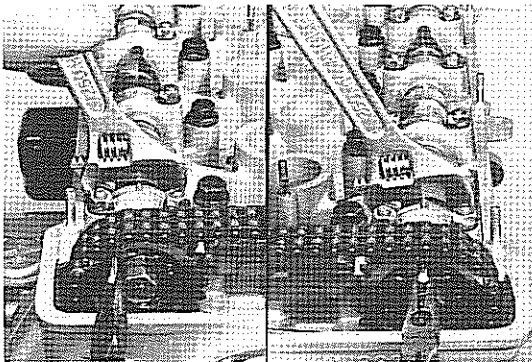

It will be easier to pull out the pin if the camshaft is turned slightly in normal direction so as to provide play.

Fig. 5-12

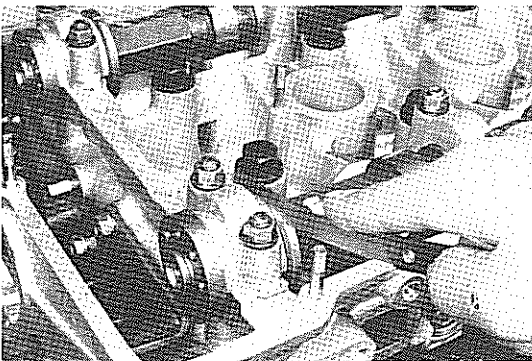

Measure the camshaft thrust clearance.

Thrust clearance: Limit 0.4 mm (0.016 in.)

Fig. 5-13

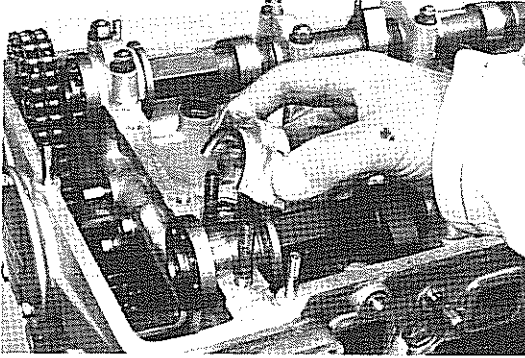

Remove the No.1 bearing cap.

Fig. 5-14

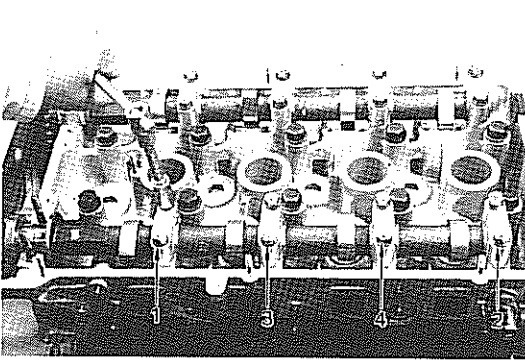

Loosen the other cap nuts a little at a time, in the sequence shown in the figure.

Fig. 5-15

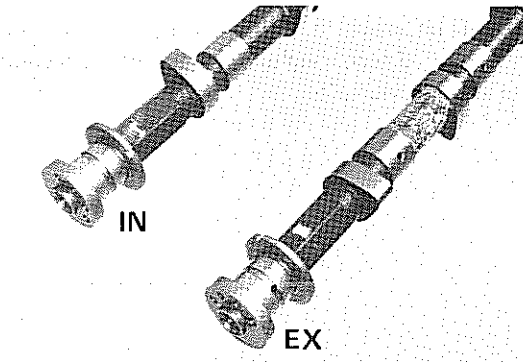

Separate the intake and exhaust camshafts.

Fig. 5-16

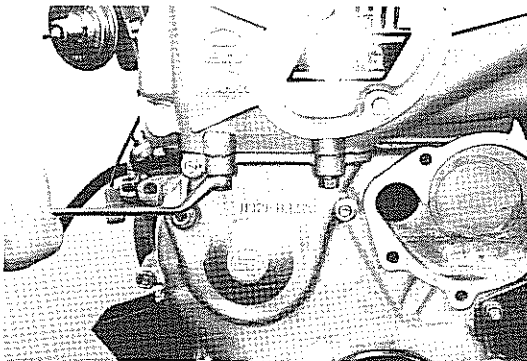

Remove the cylinder head front nuts.

Fig. 5-17

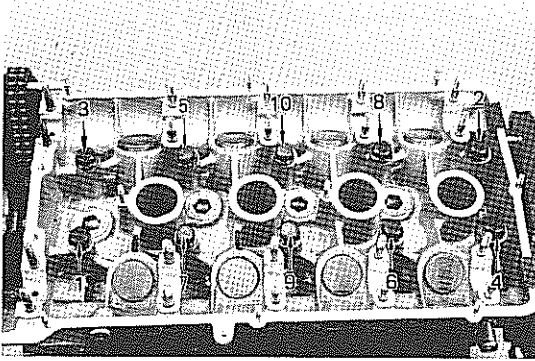

Loosen the cylinder head bolt a little at a time and in the sequence shown in the figure.

Fig. 5-18

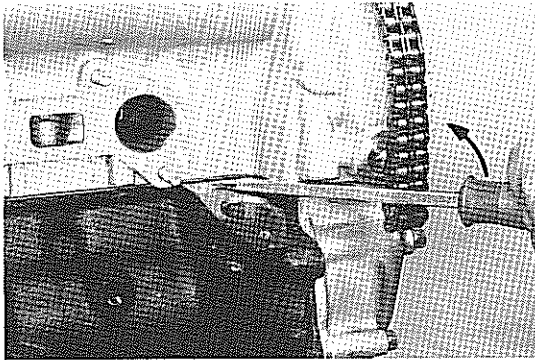

If the cylinder head is difficult to lift off, pry with a screwdriver between the head and block as shown in the figure.

Fig. 5-19

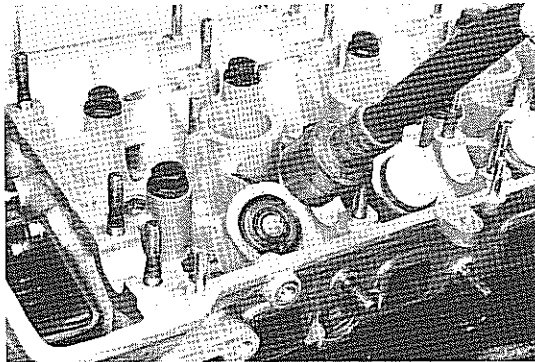

Removal is easier by holding the lifter with suction rubber and lifting it out of the hole as shown in the figure.

Fig. 5-20

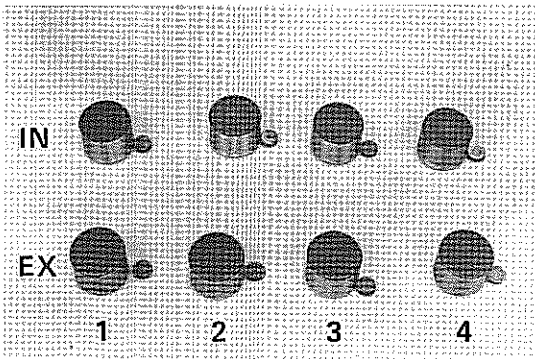

Arrange the lifters and pads in order.

Fig. 5-21

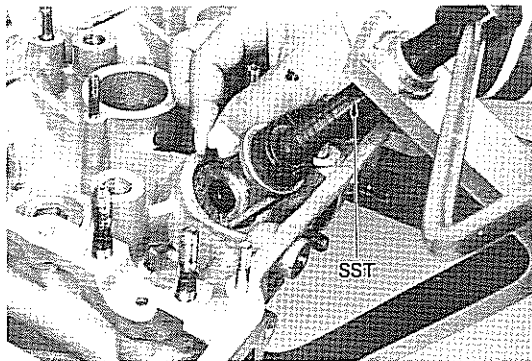

Remove the valve spring with SST.
SST [09202-43012]

Fig. 5-22

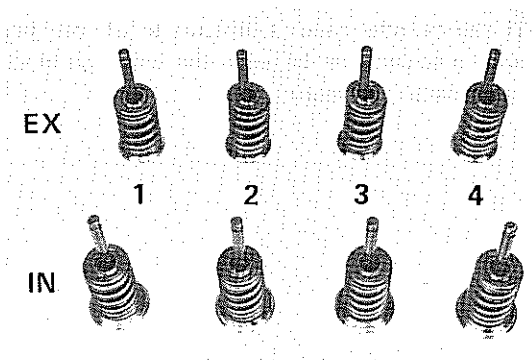

Arrange the disassembled parts in order.

Fig. 5-23

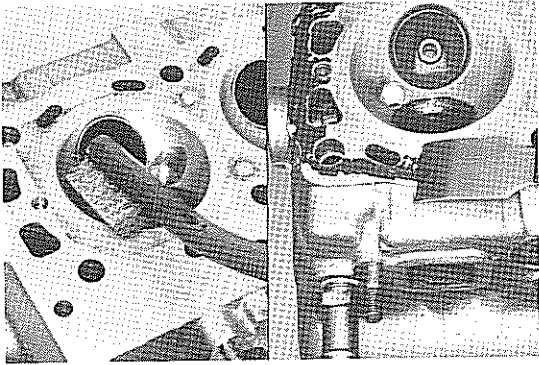

INSPECTION & REPAIR

Cylinder Head

1. Clean the combustion chamber and remove any gasket material from the manifold and head surface.

Check the cylinder head for cracks or excessively burnt valve surfaces.

Fig. 5-24

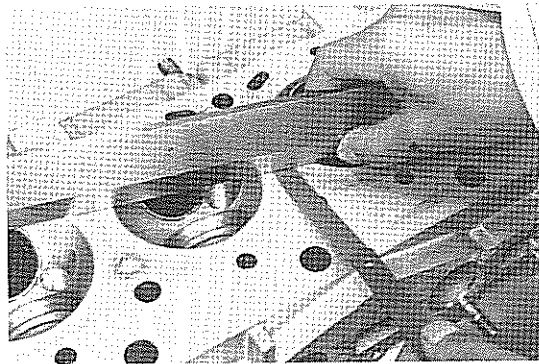

2. If warpage exceeds the limit, correct it by machining, or replace the head.

Cylinder head surface warpage:

Limit 0.05 mm
(0.002 in.)

Maximum reface:

Limit 0.2 mm
(0.01 in.)

Manifold mounting surface warpage:

Limit 0.1 mm
(0.004 in.)

Fig. 5-25

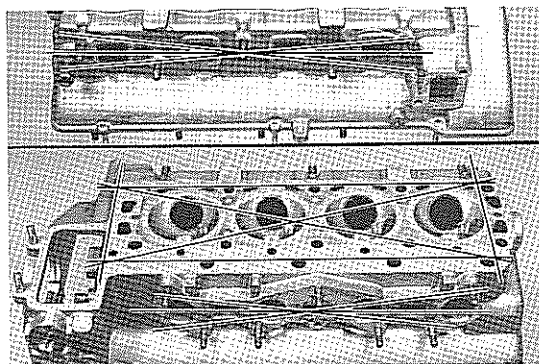

3. Check the cylinder head surface flatness with a precision straight edge.

Fig. 5-26

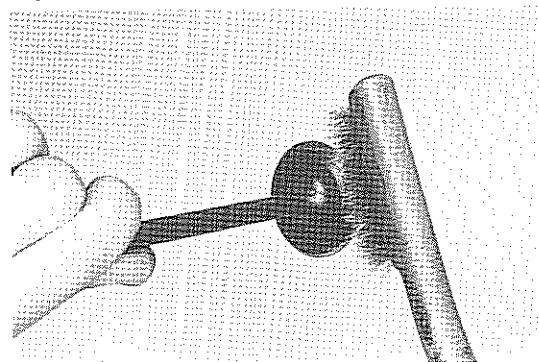

Valve, Guide & Seat

1. Clean the valves.

Fig 5-27

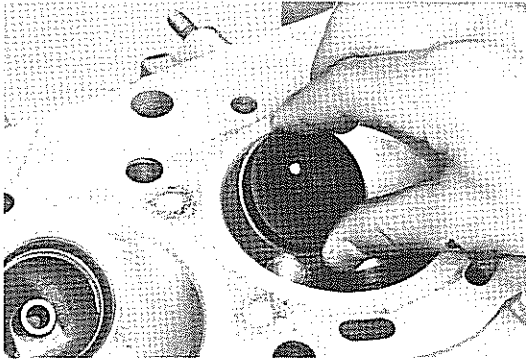

2. Check the valve stem to valve guide clearance of each valve by inserting the valve stem into the guide and moving back and forth as shown in the figure.

Fig. 5-28

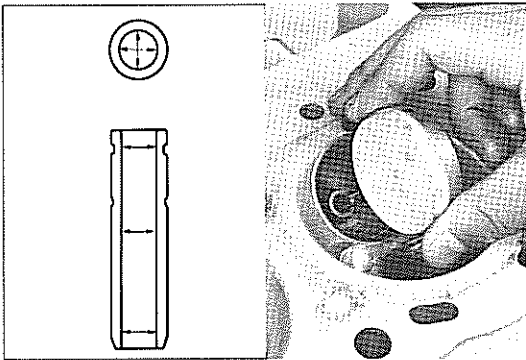

3. Measure the valve stem oil clearance.
 - (1) Measure the inside diameter of the valve guide at several places with an inside dial gauge.

Fig. 5-29

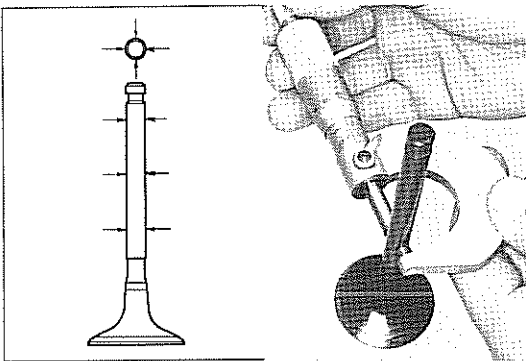

- (2) Measure the valve stem diameter.
- (3) Calculate the clearance between the valve stem and valve guide by subtracting the difference where the clearance is the largest.

Stem oil clearance:

Limit	IN	0.08 mm (0.003 in.)
	EX	0.10 mm (0.004 in.)

If the clearance exceeds the limit, replace both valve and guide.

Fig. 5-30

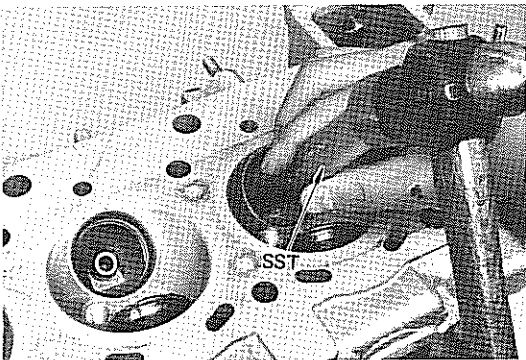

4. Replacing valve guide.
 - (1) Heat the cylinder head to about 80 – 100°C (176 – 212°F).
 - (2) From the top, drive out the guide toward the combustion chamber with SST.
SST[09201-60011]

Fig. 5-31

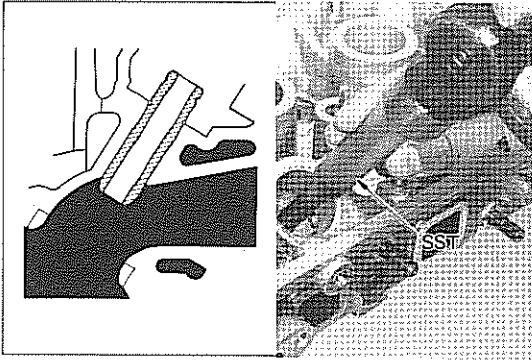

- (3) Drive in a new guide with SST until the snap ring contacts the cylinder head.
SST[09201-60011]

– Note –

1. Insure that the hole is clean.
2. Before inserting the guide apply a thin coat of oil to it and the guide hole.

Fig. 5-32

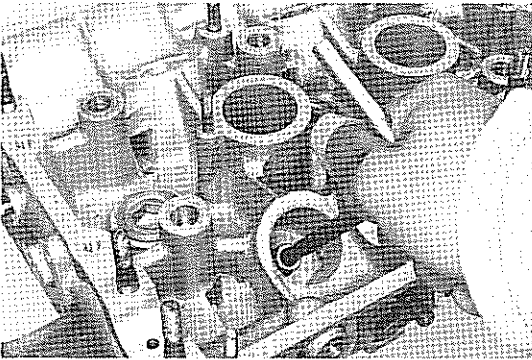

- (4) Ream the guide to the specified clearance with an 8 mm (0.3 in.) reamer.

Stem oil clearance:

STD

IN 0.025 – 0.055 mm
(0.0010 – 0.0022 in.)

EX 0.030 – 0.060 mm
(0.0012 – 0.0024 in.)

Fig. 5-33



5. Grinding valves and seats.
(1) Grind all valves to remove the pits and carbon.

Valve face angle: 44.5°

Fig. 5-34

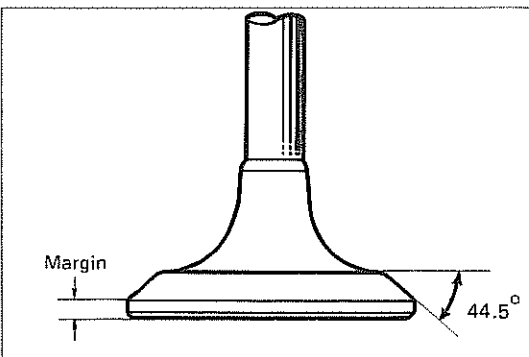

- (2) Check the valve head margin and replace if less than specified.

Head edge thickness:

Limit IN 0.8 mm
(0.03 in.)

EX 1.2 mm
(0.05 in.)

Fig. 5-35

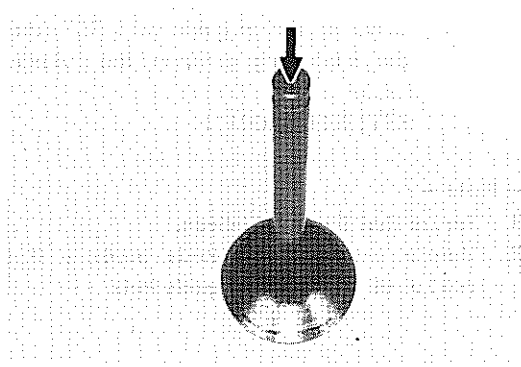

- (3) Inspect the valve stem tip.

Fig. 5-36

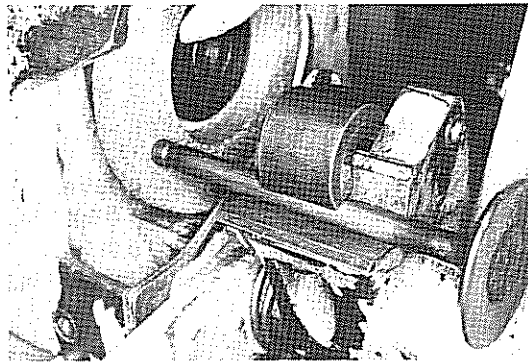

- (4) If the valve stem end is worn, resurface with a valve grinder, but do not grind off more than 0.5 mm (0.02 in.).

Overall length:

Limit	IN	105.7 mm (4.16 in.)
	EX	104.6 mm (4.12 in.)

Fig. 5-37

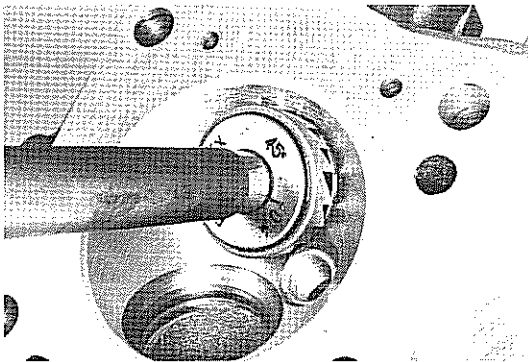

- (5) Resurface the valve seats with a 45° carbide cutter. Remove only enough metal to clean the seat.

Fig. 5-38

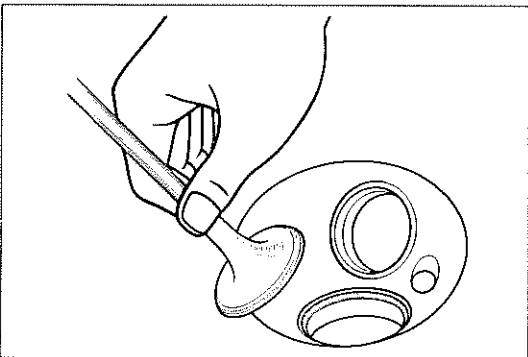

- (6) Coat the valve face with prussion blue or white lead. Locate the contact point on the valve by rotating the valve against seat.

— Note —

Seat contact should be in middle of the valve face with the following width:

IN	1.2 – 1.6 mm (0.05 – 0.06 in.)
EX	1.2 – 1.6 mm (0.05 – 0.06 in.)

Fig. 5-39

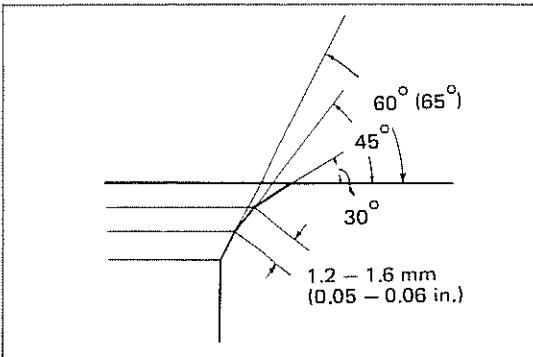

- (7) Correct the seat position.
To correct seating that is too high, use 30° and 45° cutters. If seating is too low, use 60° and 45° cutters.

Fig. 5-40

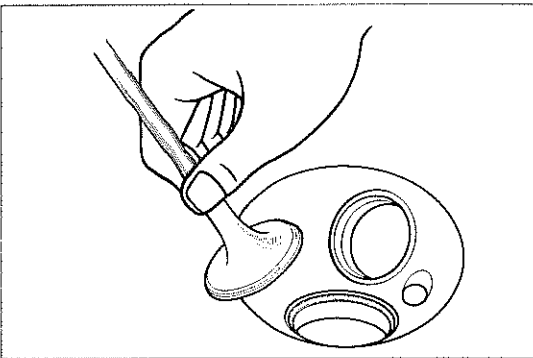

- (8) Check valve concentricity.
Lightly coat seat with prussian blue. Install valve and rotate. If blue appears 360° around face, valve stem and face are concentric. If not, replace the valve.

Fig. 5-41

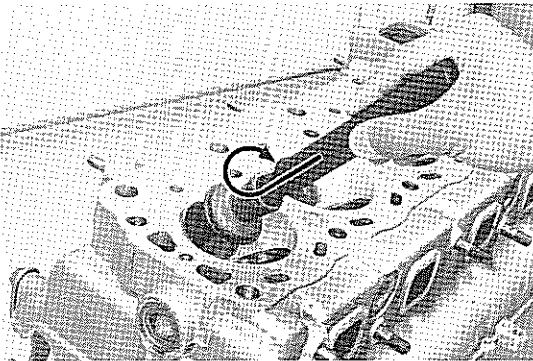

- (9) Grind the valves.
Slightly turn the valve with each tap to the seat surface.

Fig. 5-42

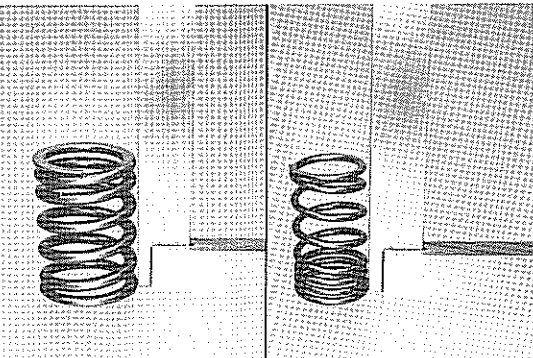

Valve Spring

1. Check the squareness of the valve springs with a steel square and surface plate. Turn the spring around slowly and observe the space between the top of the spring and the square. Replace the spring if it is out of square more than the specified limit.

Squareness limit:

Inner	1.6 mm (0.06 in.)
Outer	1.6 mm (0.06 in.)

Fig. 5-43

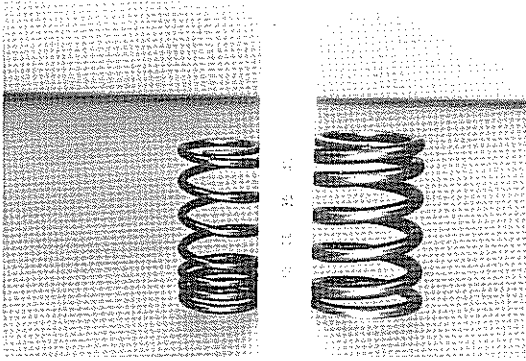

Fig. 5-44

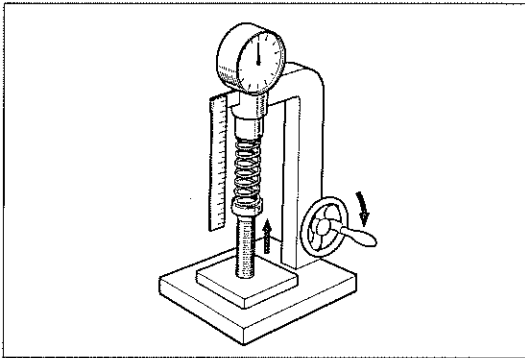

Fig. 5-45

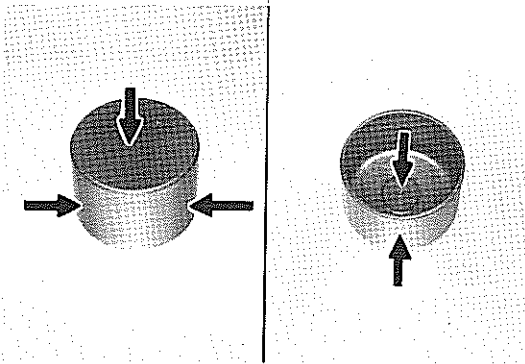
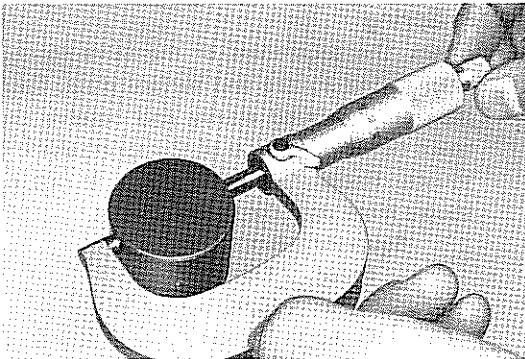

Fig. 5-46



2. Measure the spring free height. Replace springs that do not meet specification.

Free length: Inner 45.9 mm
(1.81 in.)

Outer 47.4 mm
(1.87 in.)

3. Using a spring tester, measure the tension of each spring at the specified installed height. Replace any spring that does not meet specification.

Installed length: Inner 36.5 mm
(1.44 in.)

Outer 39.0 mm
(1.54 in.)

Installed load:

STD Inner 7.3 kg
(16.1 lb)

Outer 23.7 kg
(52.3 lb)

Limit Inner 6.7 kg
(14.8 lb)

Outer 21.8 kg
(48.1 lb)



Valve Lifter

1. Inspect for wear or damage.



2. Measure the valve lifter oil clearance.
 - (1) Measure the outside diameter of the lifters.

Fig. 5-47

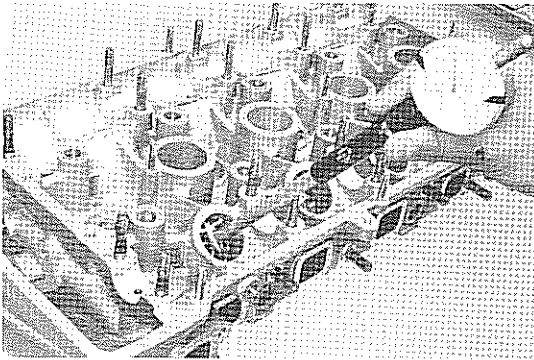

- Measure the inside diameter of cylinder head.

Oil clearance:

STD 0.02 – 0.03 mm
(0.0008 – 0.0012 in.)

Limit 0.1 mm
(0.004 in.)

Fig. 5-48

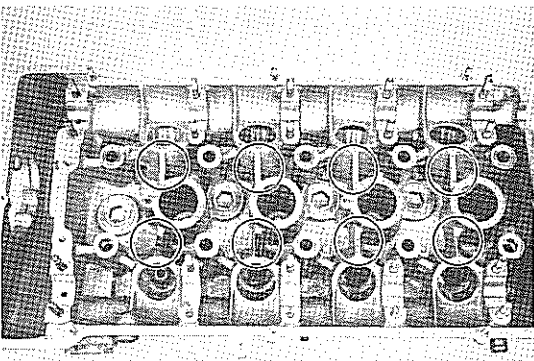

- Valve lifter selective fits.

mm (in.)

Fit code (Paint)	Cylinder head valve lifter bore	Valve lifter outer diameter
Black	37.951–37.957 (1.4941–1.4944)	37.925–37.931 (1.4931–1.4933)
Blue	37.957–37.963 (1.4944–1.4946)	37.931–37.937 (1.4933–1.4936)
Yellow	37.963–37.969 (1.4946–1.4948)	37.937–37.943 (1.4936–1.4938)
Red	37.969–37.975 (1.4948–1.4951)	37.943–37.949 (1.4938–1.4941)

Fig. 5-49

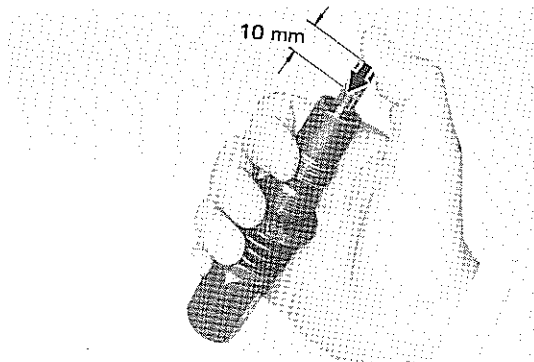

No.2 Chain Tensioner

Air Seal Test

- Immerse the plunger in engine oil and bleed the air.
- Press plunger with thumb a 10 mm (0.4 in.) stroke should take 3 seconds or more.

Fig. 5-50

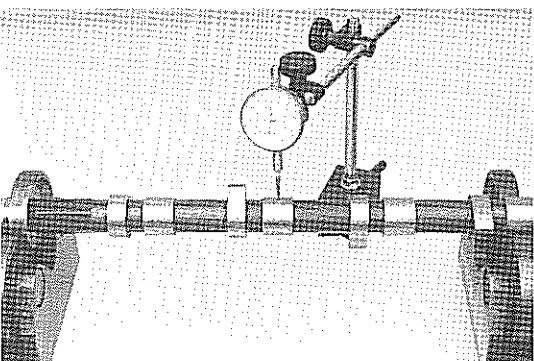

Camshaft & Bearing

- Check the camshaft for runout. Replace camshaft if it exceeds limit.

Runout limit: 0.04 mm
(0.0016 in.)

Fig. 5-51

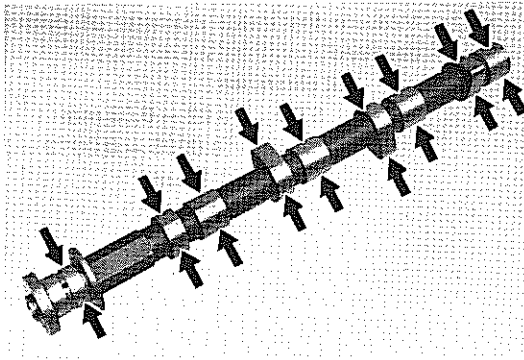

2. Inspect the cam lobe and journal for cracks, wear or chipped teeth. If damaged, replace the camshaft.

Fig. 5-52

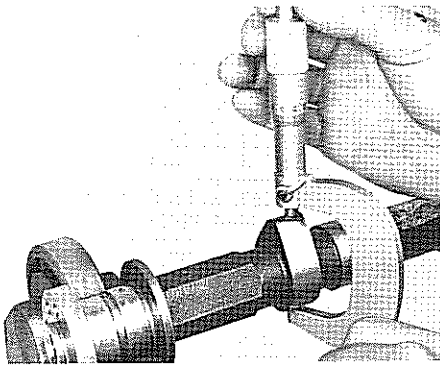

3. Measure the cam lobe height and check for wear. If wear exceeds the limit, replace the camshaft.

Cam height:

STD 46.37 – 46.47 mm
(1.826 – 1.830 in.)

Limit 46.0 mm
(1.81 in.)

Fig. 5-53

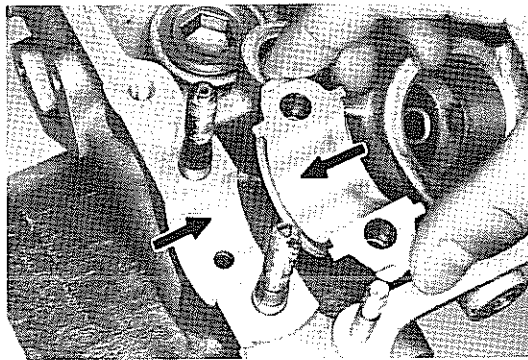

4. Check the bearing for flaking or scoring.

Fig. 5-54

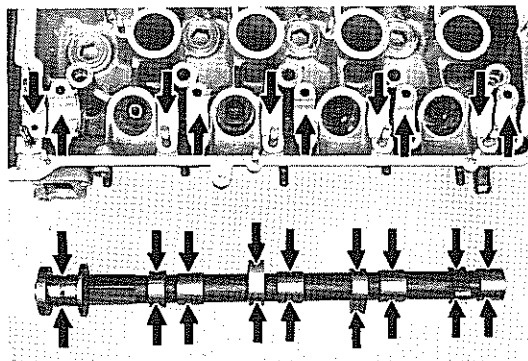

5. Measure the camshaft oil clearance.
 - (1) Clean the bearing, cap and camshaft journal.

Fig. 5-55

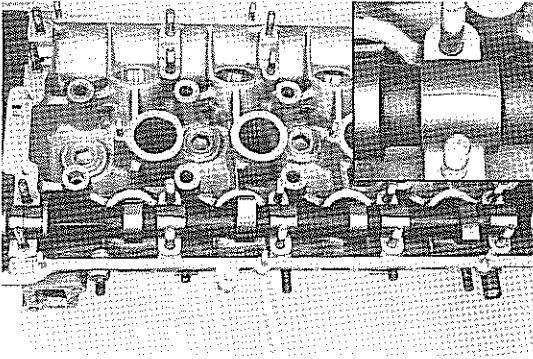

- (2) Place a piece of plastigage across the full width of the journal surface.

Fig. 5-56

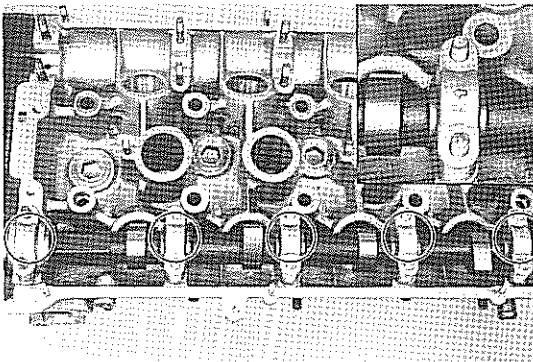

- (3) When installing the bearing caps, insure that the front marks and imprinted numbers match.

Fig. 5-57

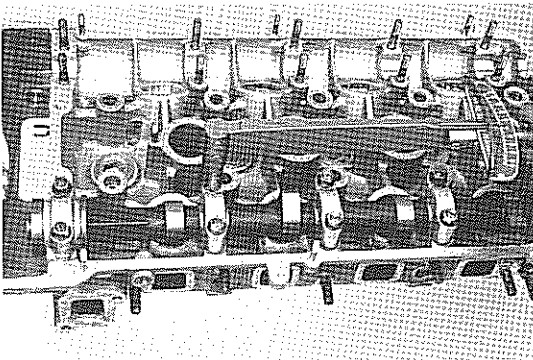

- (4) Install the bearing cap and tighten bolts to specified torque.

Tightening torque:

1.2 – 1.8 kg-m

(9 – 13 ft-lb)

– Note –

Do not turn camshaft while plastigage is in place.

- (5) Remove the bearing caps.

Fig. 5-58

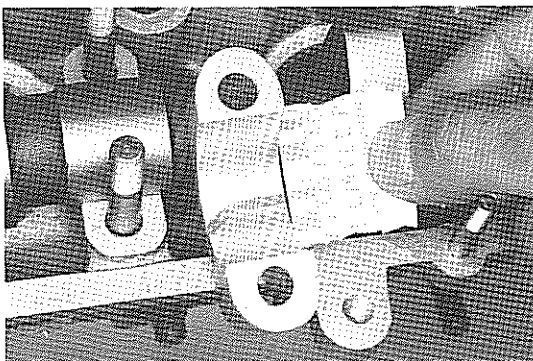

- (6) With the plastigage scale, measure the width of the plastigage at its widest point. If clearance exceeds the specification limit, adjust with a suitable bearing size.

Oil clearance:

STD 0.025 – 0.062 mm
(0.0010 – 0.0024 in.)

Limit 0.15 mm
(0.006 in.)

Fig. 5-59

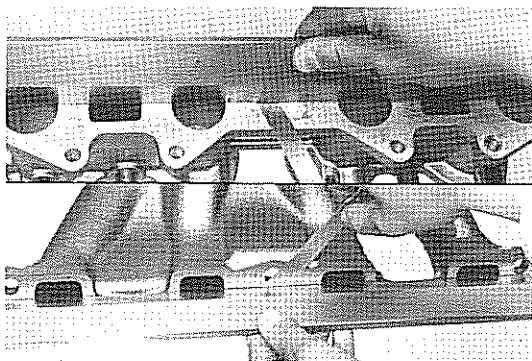
**Manifold**

1. Inspect the cylinder head contacting surfaces for warpage and replace the manifold if it exceeds the limit.

Installing surface warpage:

Limit 0.1 mm
(0.004 in.)

Fig. 5-60

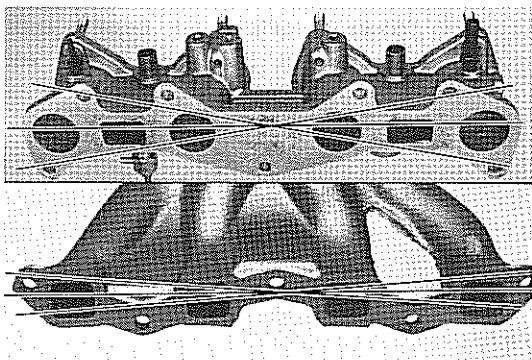

2. Check manifold surface for flatness with a precision straight edge.

ASSEMBLY

Assemble the parts in the numerical order shown in the figure.

Fig. 5-61

- Thoroughly clean the parts to be assembled.
- Apply clean engine oil on the sliding and rotating surfaces of the parts before assembly.

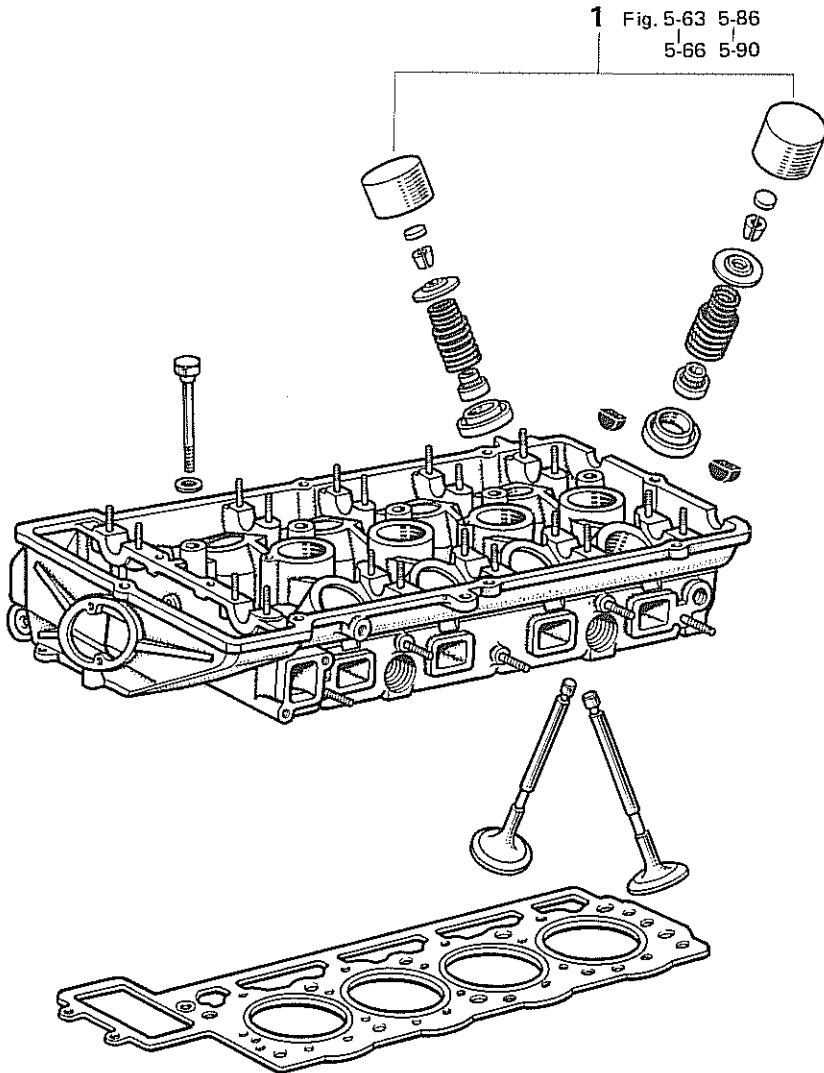

- | | |
|---------------------------|--------------------------|
| 1. Valve & Spring | 8. No.2 Chain Tensioner |
| 2. Cylinder Head | 9. No.2 Vibration Damper |
| 3. No.3 Vibration Damper | 10. Cylinder Head Cover |
| 4. Oil Nozzle | 11. Exhaust Manifold |
| 5. Front Cover | 12. Intake Manifold |
| 6. Camshaft & Bearing Cap | 13. Spark Plug |
| 7. Camshaft Timing Gear | |

Fig. 5-62

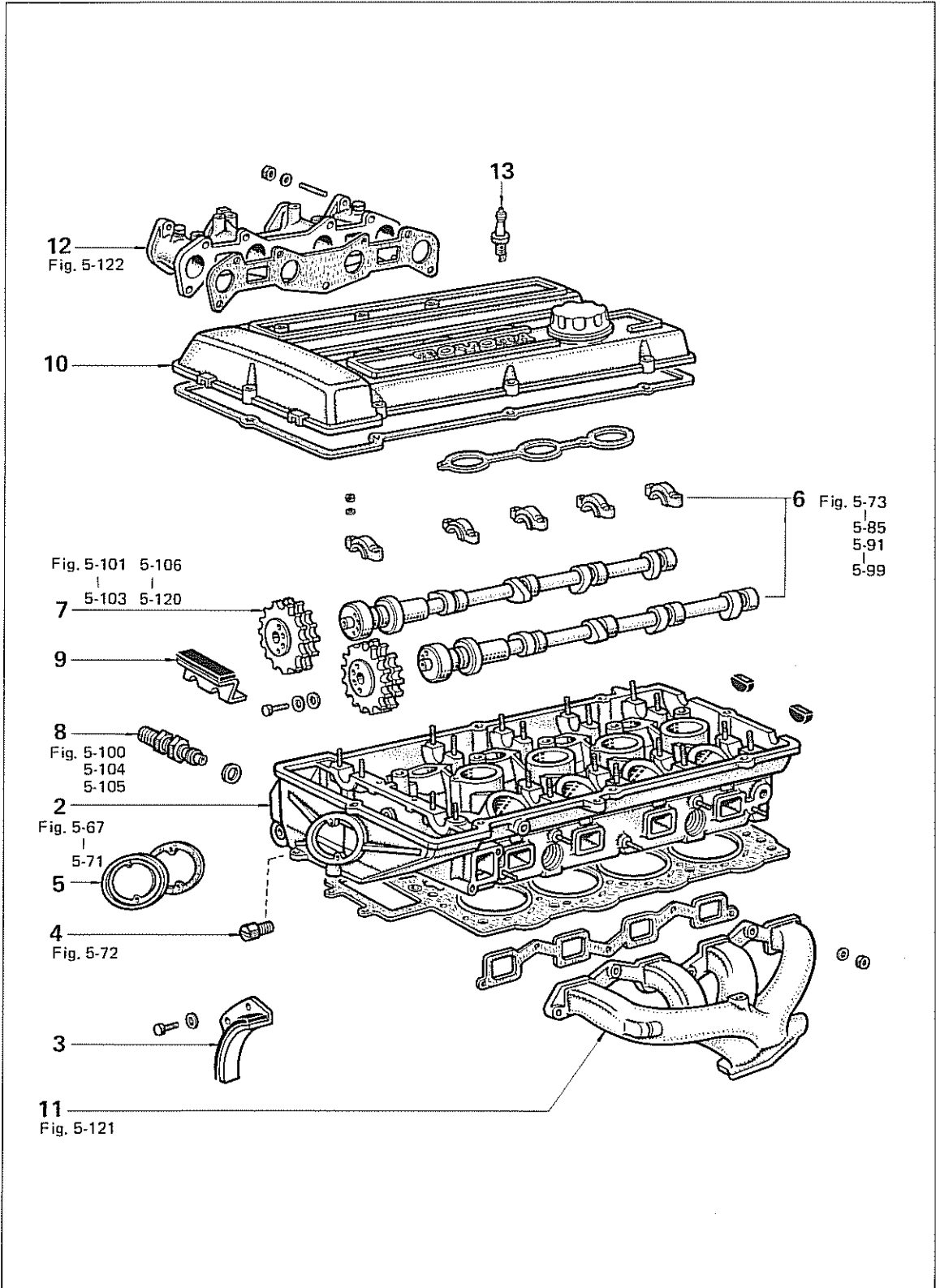
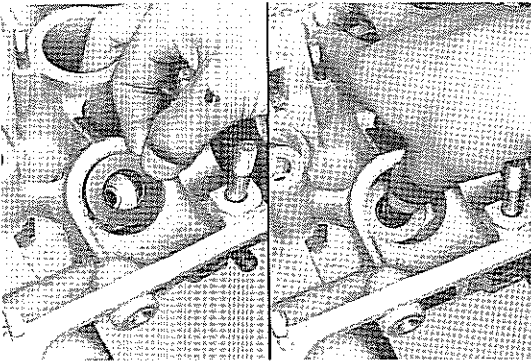
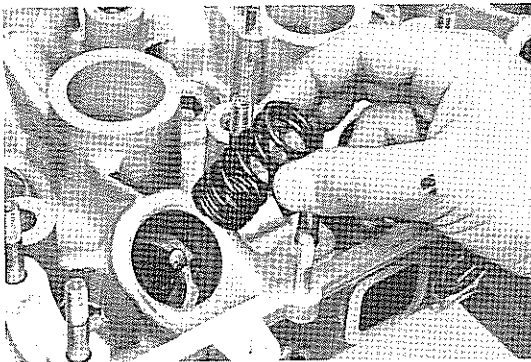

Fig. 5-63



Install the spring seat and oil seal as shown in the figure. The head must be clean and the oil seal inserted to where the end contacts the spring seat top.

Fig. 5-64



Install the inner spring as shown in the figure.

Fig. 5-65

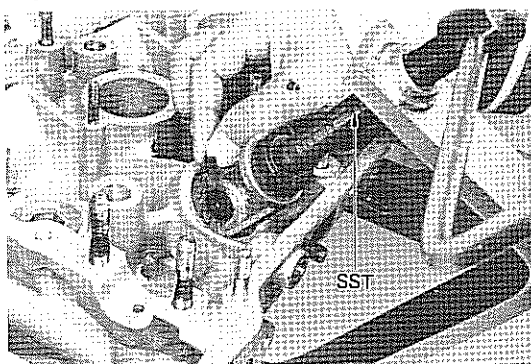

Assemble the valve spring and install the retainers with SST.
SST [09202-43012]

Fig. 5-66

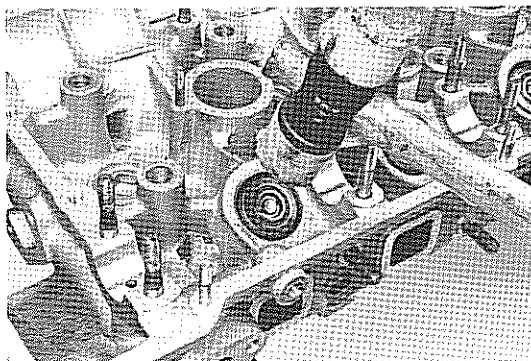

Tap the valve stems lightly to assure proper fit.

Fig. 5-67

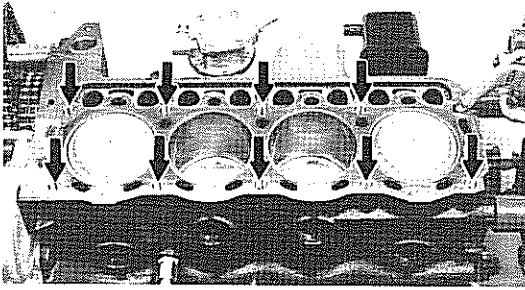

Clean the bolt holes with compressed air.

Fig. 5-68

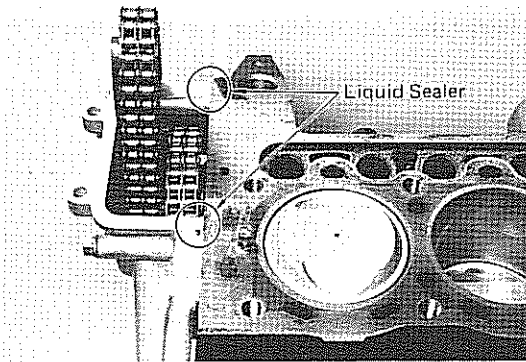

Apply a coat of sealer to the cylinder head, around the holes in the block, and in the vicinity of the timing chain cover and cylinder block.

Fig. 5-69

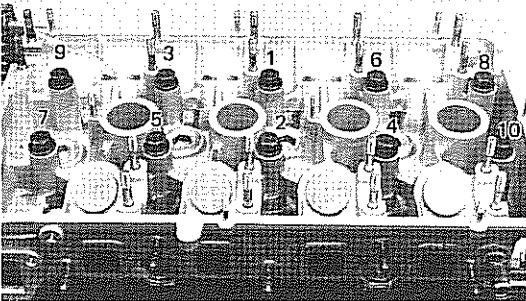

Tighten the each cylinder head bolt a little at a time in the sequence shown in the figure.

Fig. 5-70

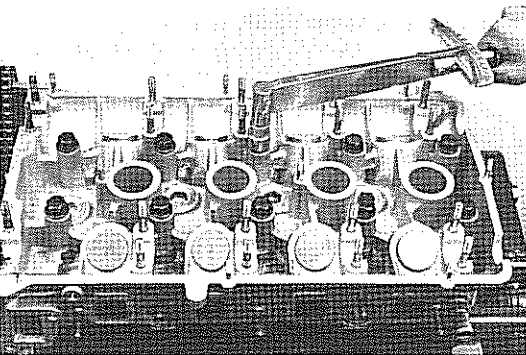

Tighten the cylinder head bolts to specified torque.

**Tightening torque: 7.2 – 8.8 kg-m
(53 – 63 ft-lb)**

Fig. 5-71

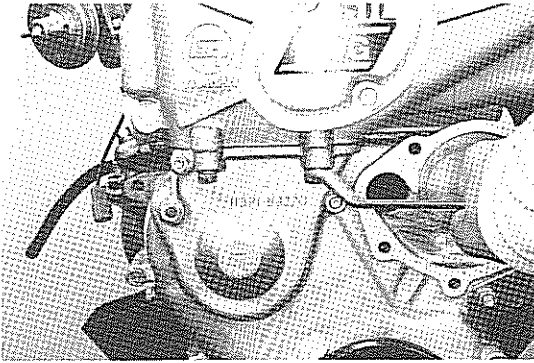

Install the cylinder head front nuts.

Fig. 5-72

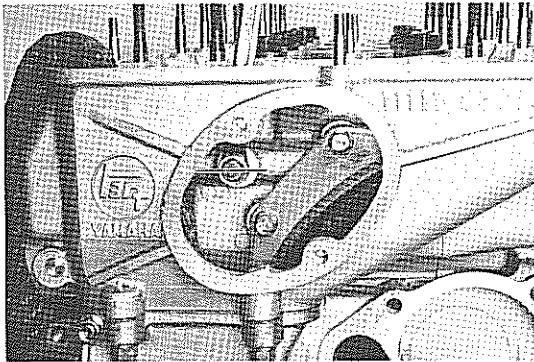

Install the oil nozzle with its slot positioned horizontally.

Fig. 5-73

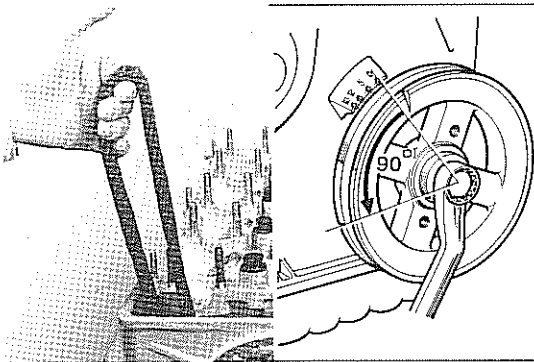

Rotate the crankshaft about 90° in the reverse direction.

– Note –

1. Lower the piston to prevent interference of piston head and valve.
2. When rotating the crankshaft in the reverse direction, hold the chain.

Fig. 5-74

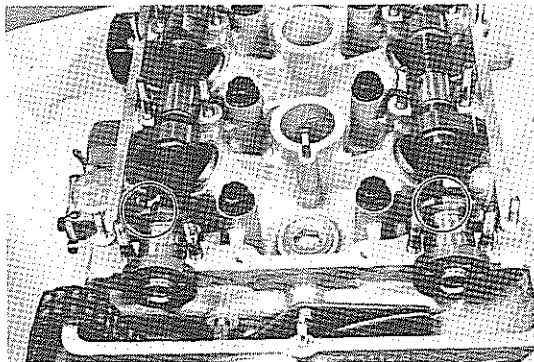

Position the camshaft so that the slit in the front end will point upward.

Fig. 5-75

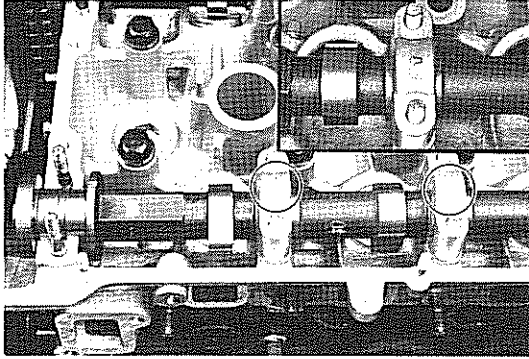

Face the arrow mark of bearing cap toward the front.

Fig. 5-76

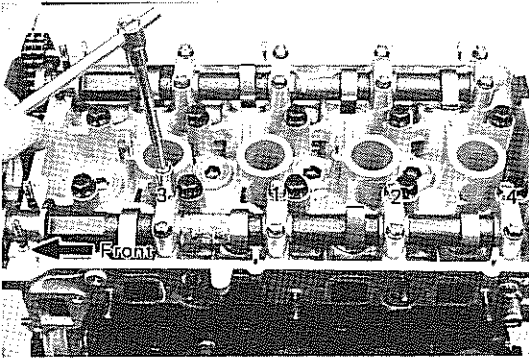

Tighten the No.2 – No.5 bearing cap bolts a little at a time, in the sequence shown in the figure.

Fig. 5-77

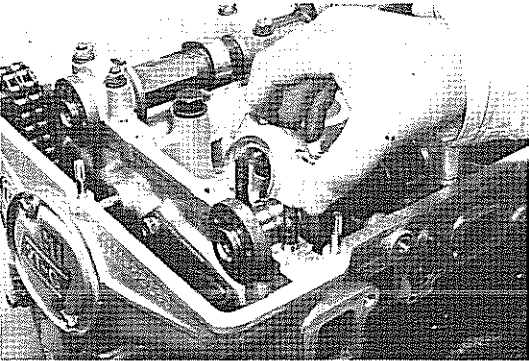

Then, install the No.1 bearing cap.

– Note –

If the No.1 bearing cap will not go in, move the camshaft back and forth until the cap goes in smoothly.

Fig. 5-78

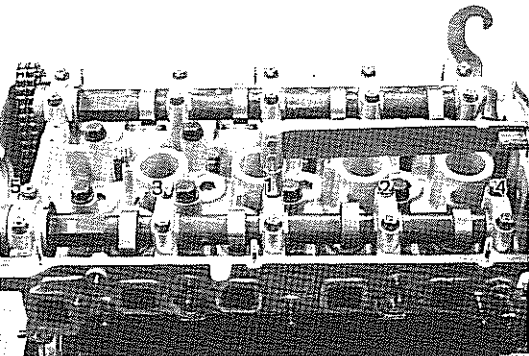

Tighten the cap nuts to specified torque.

Tightening torque: 1.6 – 2.2 kg-m
(12 – 15 ft-lb)

Fig. 5-79

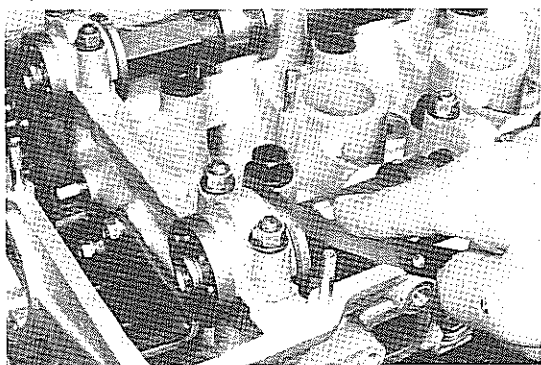

Check the camshaft thrust clearance.

Thrust clearance:

STD 0.15 – 0.35 mm
(0.006 – 0.014 in.)

Limit 0.4 mm
(0.02 in.)

Fig. 5-80

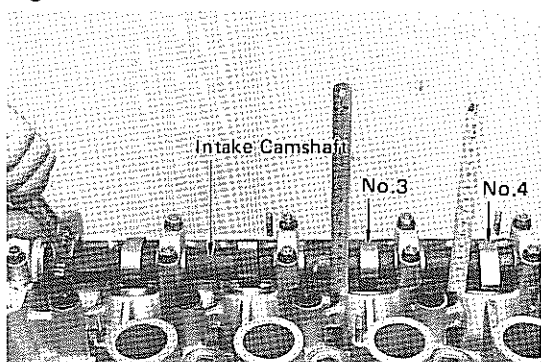

Adjust The Valve Clearance

1. Measure the valve clearance.
 - (1) Intake side valve lifters No.3 and No.4 should protrude the same amount.

Fig. 5-81

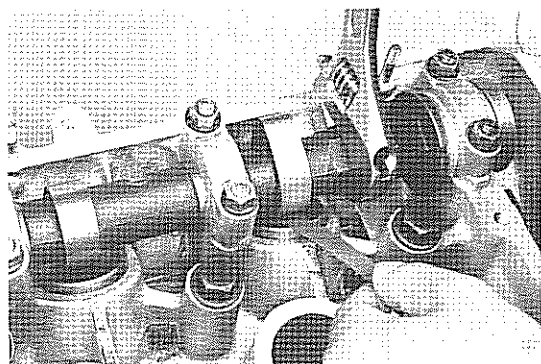

- (2) Measure the exhaust side valve clearance while turning the camshaft with a tool.

Exhaust valve clearance:

0.29 – 0.39 mm
(0.011 – 0.015 in.)

If outside the specified value, record the amount.

Fig. 5-82

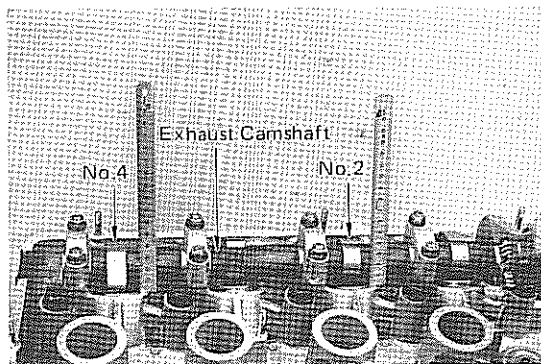

- (3) Exhaust side valve lifters No.2 and No.4 should protrude the same amount.

Fig. 5-83

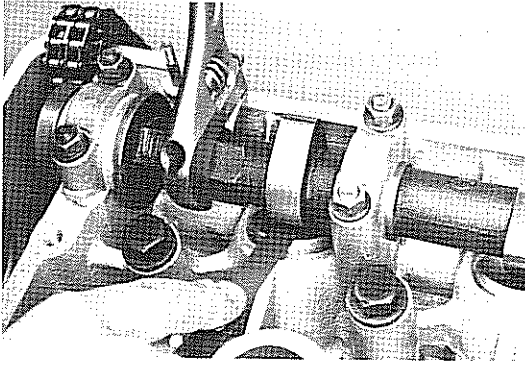

- (4) Measure the intake side valve clearance while turning the camshaft with a tool.

Intake valve clearance:

0.24 – 0.34 mm

(0.009 – 0.013 in.)

If outside the specified value, record the amount.

Fig. 5-84

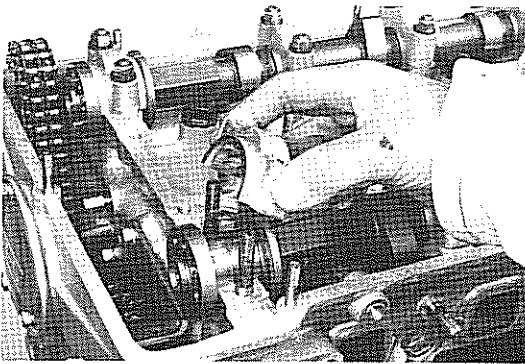

2. Remove the No.1 bearing cap.

Fig. 5-85

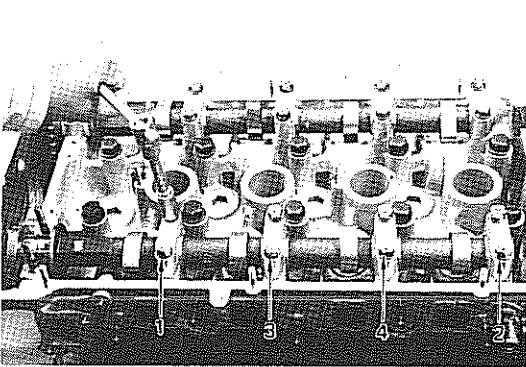

3. Loosen the other cap nuts a little at a time, in the sequence shown in the figure.
4. Remove the camshaft.

Fig. 5-86

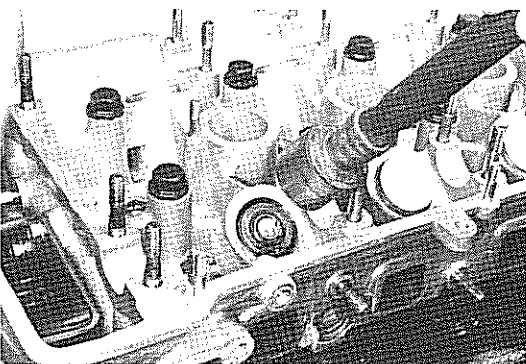

5. Remove the valve lifter when the valve clearance is not within specified value.

Fig. 5-87

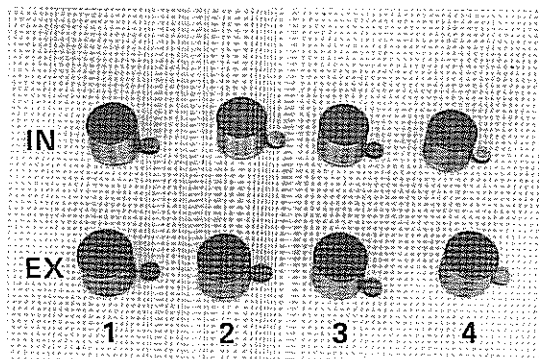

6. Arrange the valves and adjusting pads in order.

Fig. 5-88

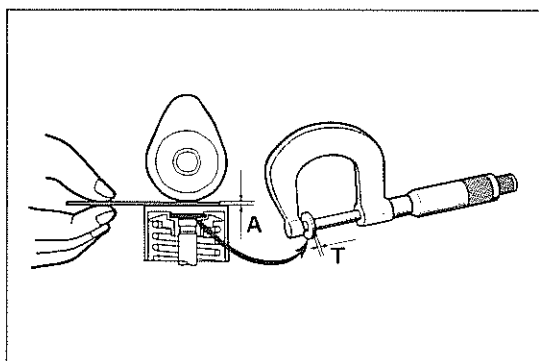

7. Select a new pad that will give the specified valve clearance as follows.

- (1) Measure the pad that was off with a micrometer.

- (2) Calculate thickness of the new pad so the valve clearance comes within specified value.

T Thickness of pad used.

A Valve clearance measured.

Intake Side

$$\text{New Pad Thickness} = T + (A - 0.29 \text{ mm})$$

(0.011 in.)

Exhaust Side

$$\text{New Pad Thickness} = T + (A - 0.34 \text{ mm})$$

(0.014 in.)

Fig. 5-89

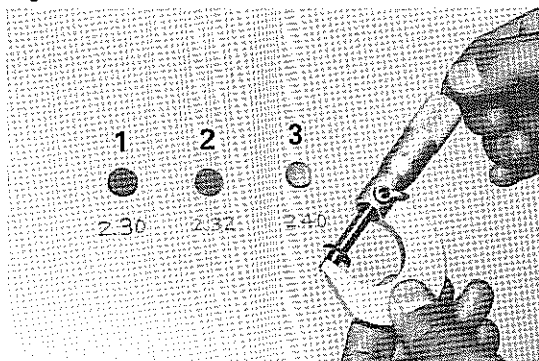

- (3) Select a pad with a thickness as close as possible to the valve calculated.

Pads are available in 41 sizes, in increments of 0.05 mm (0.002 in.), from 1.00 mm (0.039 in.) to 3.00 mm (0.118 in.).

Fig. 5-90

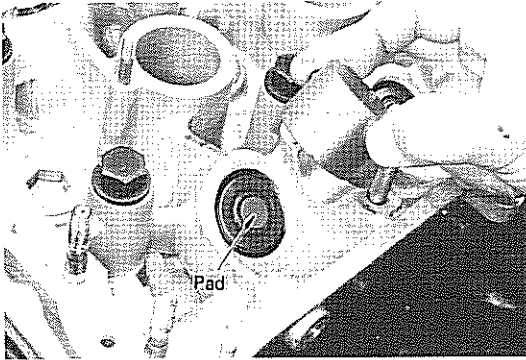

8. Install the parts and valve lifters.

Fig. 5-91

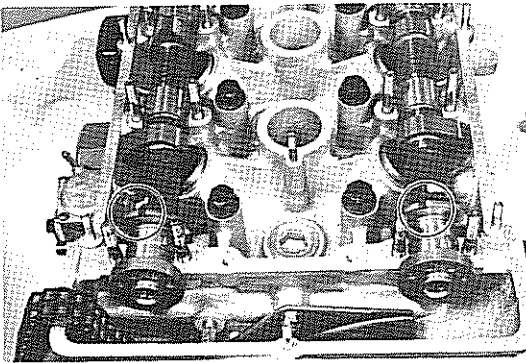

Position the camshaft so that the slit in the front end will point upward.

Fig. 5-92

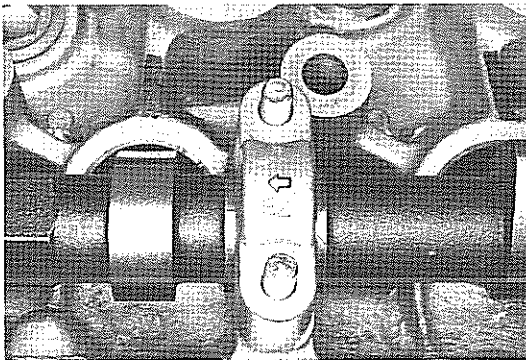

Face the arrow mark of bearing cap toward front.

Fig. 5-93

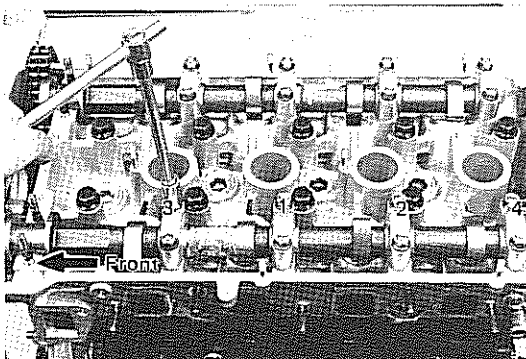

Temporarily tighten the No.2 – No.5 bearing cap bolts a little at a time, in the sequence shown in the figure.

Fig. 5-94

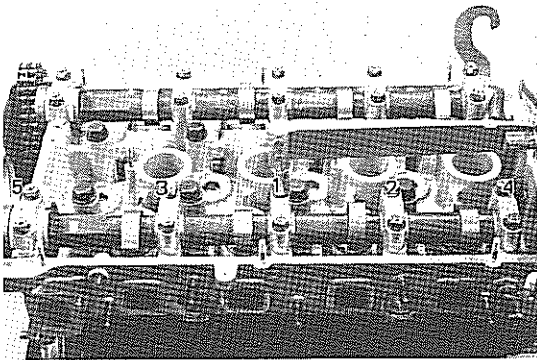

Then install the No.1 bearing cap.
Tighten the cap nuts to specified torque.

**Tightening torque: 1.6 – 2.2 kg-m
(12 – 15 ft-lb)**

– Note –

If the No.1 bearing cap will not go in, move the camshaft back and forth until the cap goes in smoothly.

Fig. 5-95

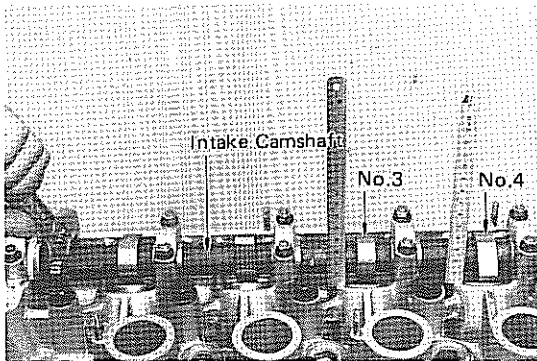

Recheck The Valve Clearance

Measure the valve clearance.

1. Intake valve lifter No.3 and No.4 should protrude the same amount.

Fig. 5-96

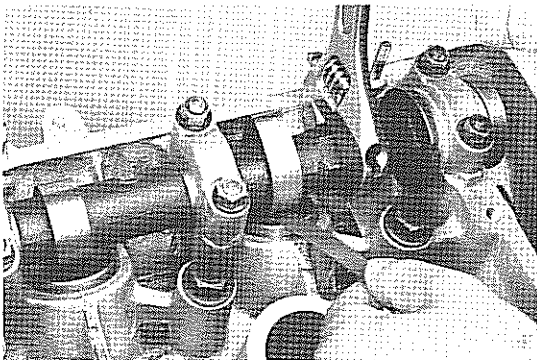

2. Measure the exhaust side valve clearance while turning the camshaft with a tool.

Exhaust valve clearance:

**0.29 – 0.39 mm
(0.011 – 0.015 in.)**

If outside the specified value, choose another pad.

Fig. 5-97

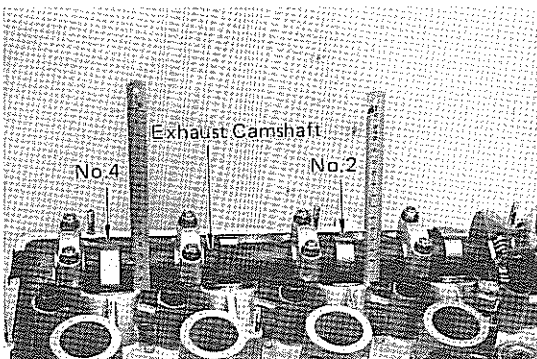

3. Exhaust valve lifter No.2 and No.4 should protrude the same amount.

**Approx: 1.6 mm
(0.06 in.)**

Fig. 5-98

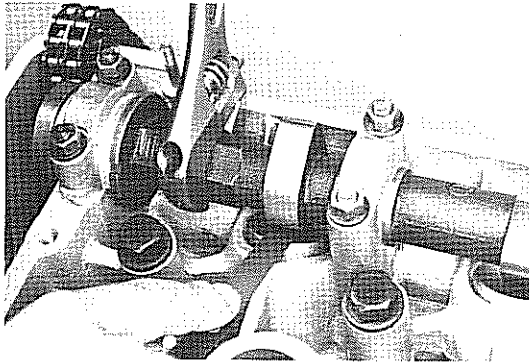

4. Measure the intake valve clearance while turning the camshaft with a tool.

Intake valve clearance:

0.24 – 0.34 mm

(0.009 – 0.013 in.)

If outside the specified value, choose another pad.

Fig. 5-99

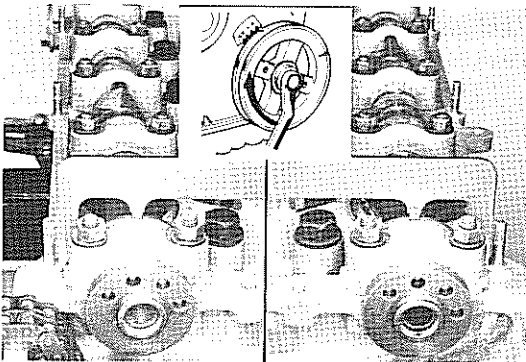

Position the No.1 and No.2 camshaft slit upward with SST.

Set the No.1 cylinder to TDC/compression.
SST[09248-27010]

Fig. 5-100



Install the chain tensioner No.2.

– Note –

Insert oil into the cylinder before installing.

Fig. 5-101

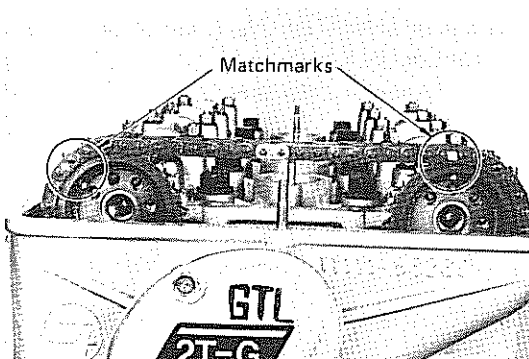

Install the No.2 chain with its mark aligned with the gear mark.

Align the camshaft pin hole and gear pin hole to position before disassembly and insert the pin.

– Note –

If the pin holes do not line up, turn the camshaft and make the nearest holes line up, but do not turn more than 45°.

Fig. 5-102

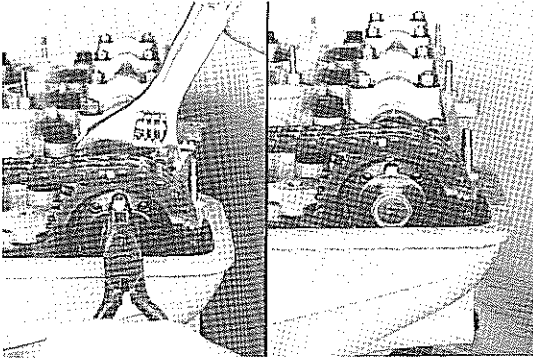

Hold the pin with the washer.

Fig. 5-103

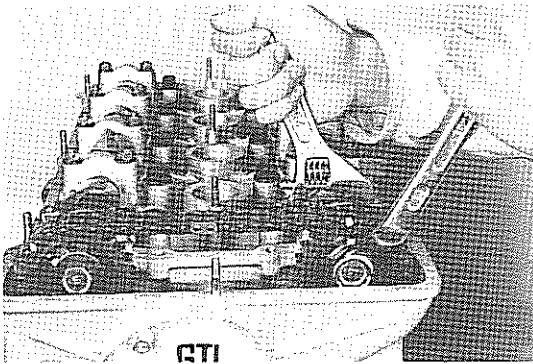

Turn the crankshaft slightly in normal direction, until there is no slack in the pins, gears, and camshafts, and then tighten the bolts to specified torques.

Tightening torque: 7.0 – 8.0 kg-m
(51 – 57 ft-lb)

Fig. 5-104

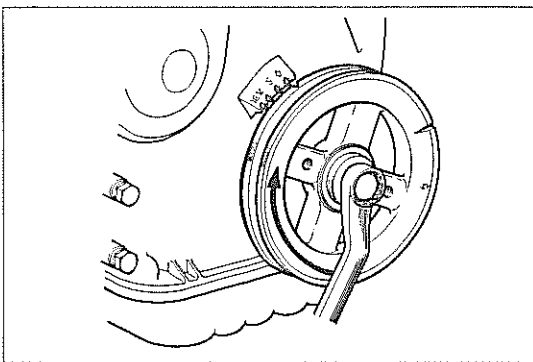

Rotate the crankshaft 360° in normal direction until No.1 cylinder is at TDC/compression.

Fig. 5-105

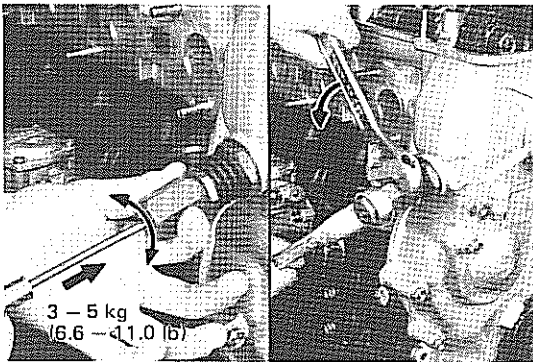

Adjust the No.2 chain tensioner.

Back stroke: 0.5 – 1.0 mm
(0.02 – 0.04 in.)

– Note –

Return the nut 1/3 to 2/3 turn back from where it contacts the No.2 plunger.

Fig. 5-106

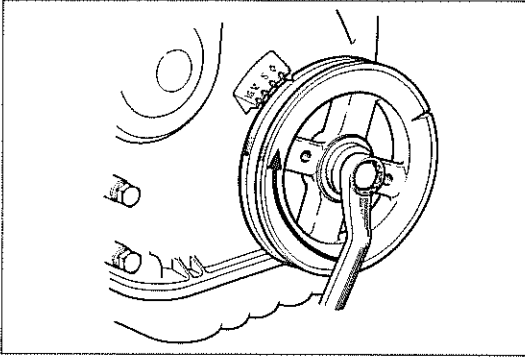
**Adjust The Valve Timing**

1. Rotate the crankshaft 360° in normal direction until No.1 cylinder is at TDC/compression.

Fig. 5-107

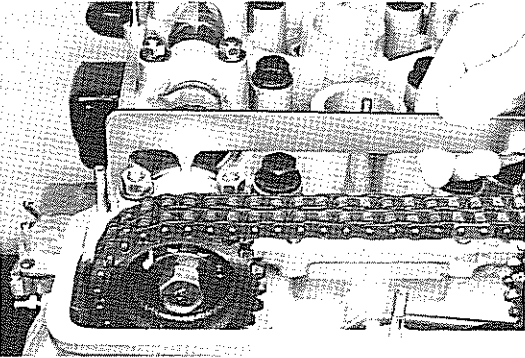

2. Check the No.1 camshaft valve timing with SST.
SST [09248-27010]

Fig. 5-108

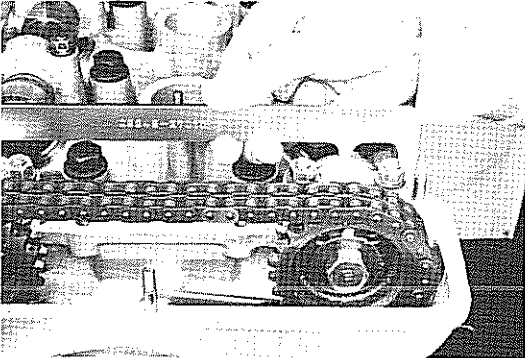

3. Check the No.2 camshaft valve timing with SST.
SST [09248-27010]

Fig. 5-109

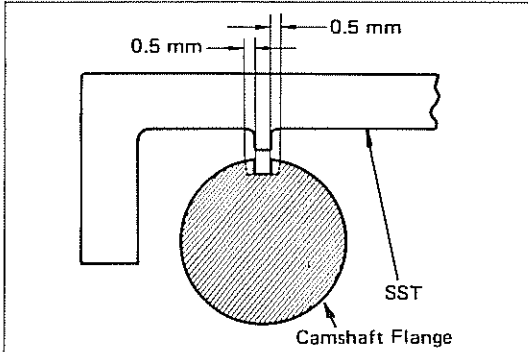

4. Valve timing permissible error,
 $\pm 2^\circ$ Camshaft rotation angle.
 ± 0.5 mm Camshaft flange outer
 (0.02 in.) perimeter.
 Adjust the valve timing if it is off.

Fig. 5-114

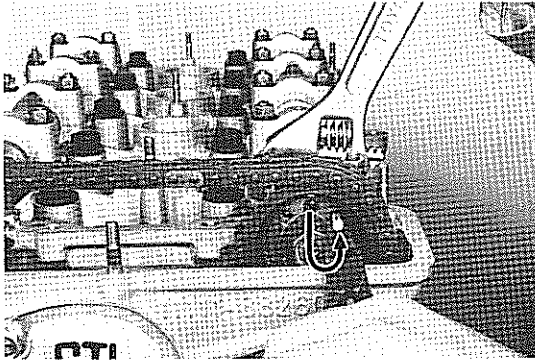

9. When the valve timing is retarded.
- (1) Align with hole pin in clockwise direction.
 - (2) Turn the camshaft so that its slit will be lined up with the adjust gauge and reinsert the pin.

Fig. 5-115

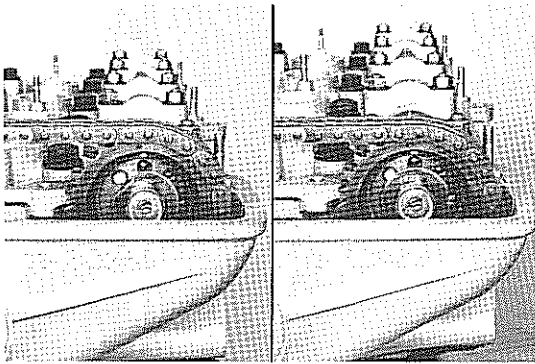

10. Hold the pin with the washer.

Fig. 5-116

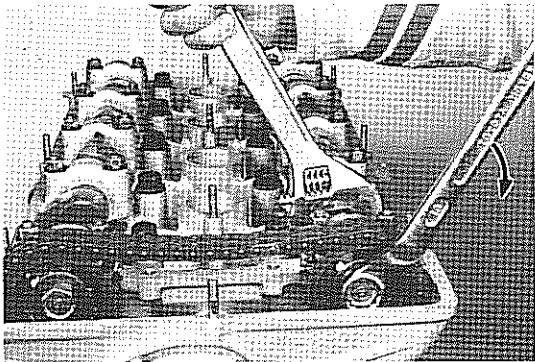

11. Tentatively tighten the camshaft timing gear set bolt.

Fig. 5-117

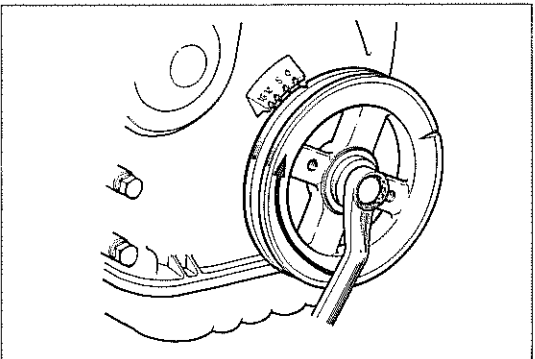

12. Rotate the crankshaft in the normal direction until No.1 cylinder is at TDC/compression.

Fig. 5-110

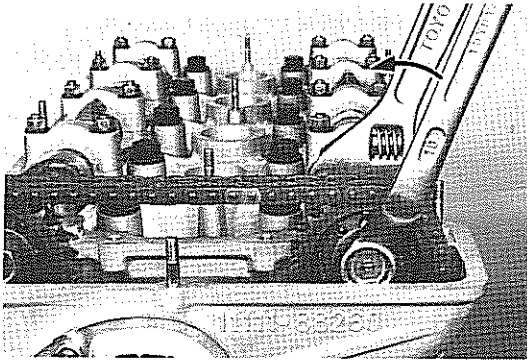

5. Loosen the camshaft mounting bolt.

Fig. 5-111

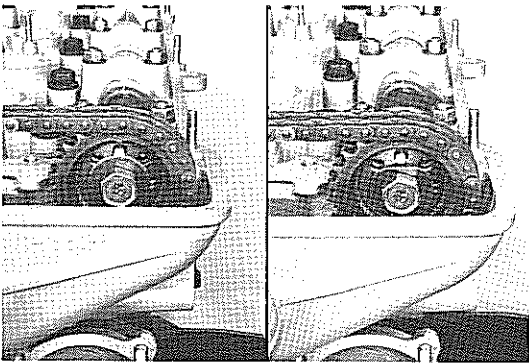

6. Shift the washer.

Fig. 5-112

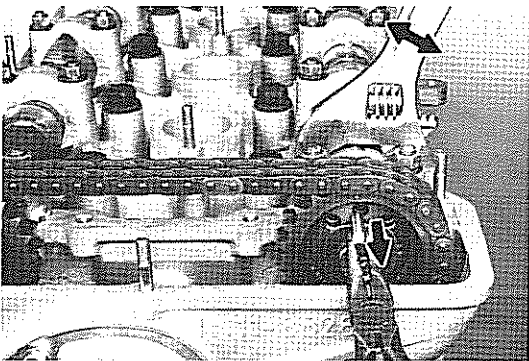

7. It will be easier to pull out the pin if the camshaft is turned slightly in the forward direction so as to provide play.

Fig. 5-113

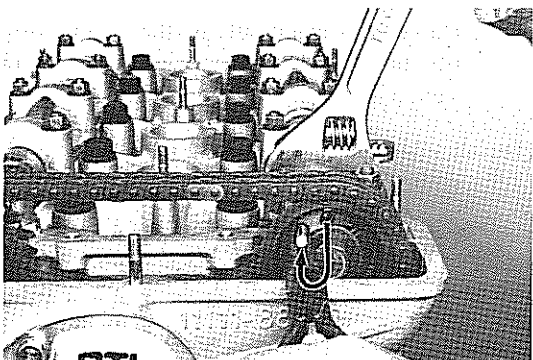

8. When the valve timing is advanced.
 - (1) Align with pin hole in counterclockwise direction.
 - (2) Turn the camshaft so that its slit will be lined up with the adjust gauge and reinsert the pin.

Fig. 5-118

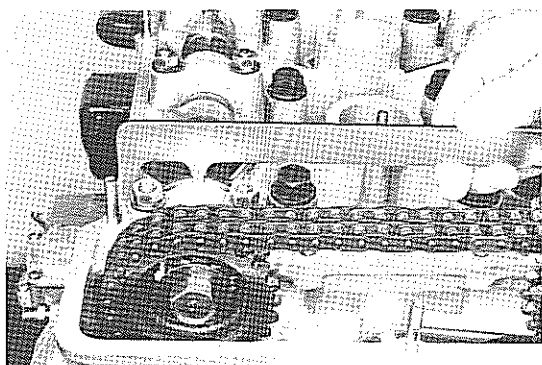

13. Recheck the No.1 camshaft valve timing with SST.
The camshaft slit and SST protrusion should align.
SST[09248-27010]

Fig. 5-119

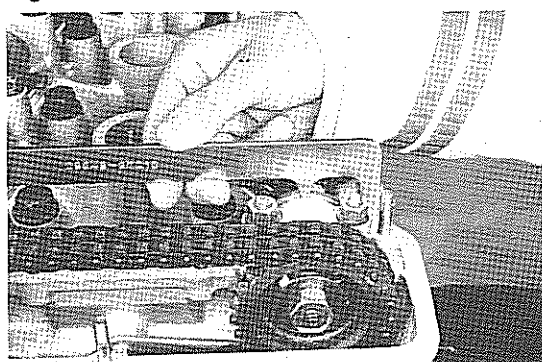

14. Recheck the No.2 camshaft valve timing with SST.
The camshaft slit and SST protrusion should align.
SST[09248-27010]

Fig. 5-120

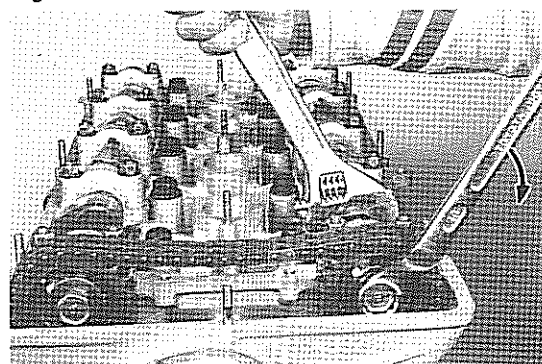

15. Tighten the camshaft timing gear set bolt.
Tightening torque:
7.0 – 8.0 kg-m
(51 – 57 ft-lb)

Fig. 5-121

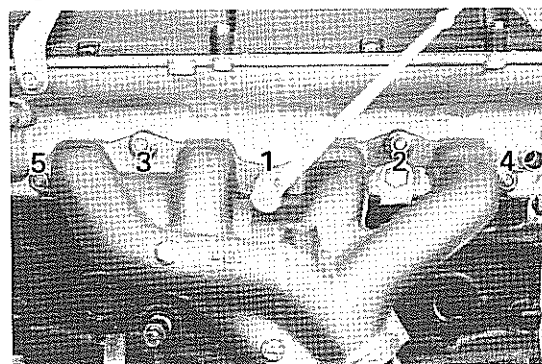

- Tighten each exhaust manifold nut a little at a time to the specified torque in the sequence shown in the figure.

Tightening torque: 3.5 – 4.5 kg-m
(26 – 32 ft-lb)

Fig. 5-122

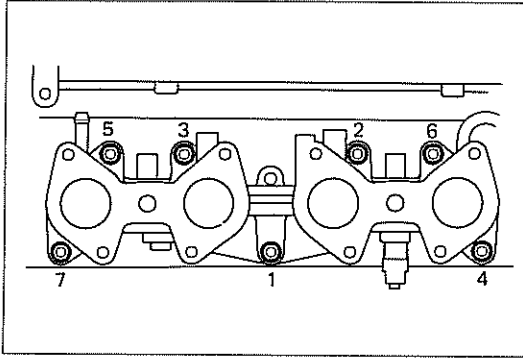

Tighten each intake manifold nut a little at a time to the specified torque in the sequence shown in the figure.

Tightening torque: 1.6 – 2.2 kg-m
(12 – 15 ft-lb)

TIMING CHAIN

DISASSEMBLY

Disassemble the parts in the numerical order shown in the figure.

Fig. 5-123

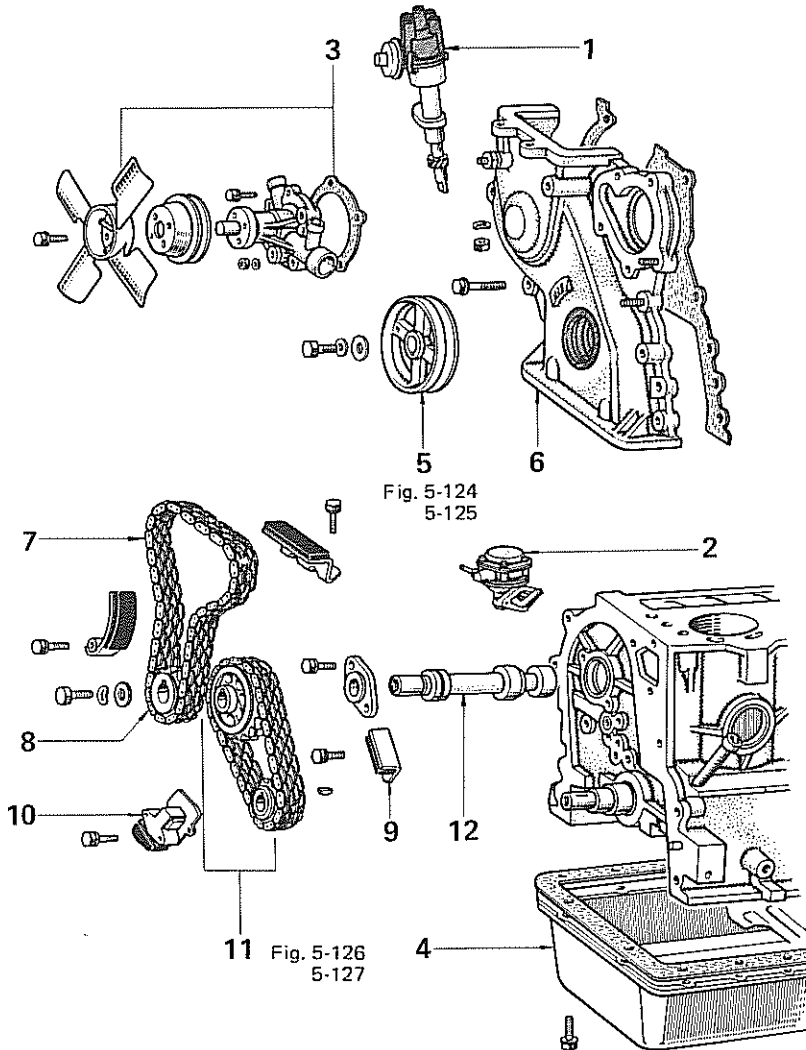

- | | | |
|---------------------|------------------------|------------------------------|
| 1. Distributor | 5. Crankshaft Pulley | 9. No.1 Chain Damper |
| 2. Fuel Pump | 6. Timing Chain Cover | 10. No.1 Chain Tensioner |
| 3. Fan & Water Pump | 7. No.2 Timing Chain | 11. No.1 Timing Chain & Gear |
| 4. Oil Pan | 8. Camshaft Drive Gear | 12. Pump Drive Shaft |

Fig. 5-124

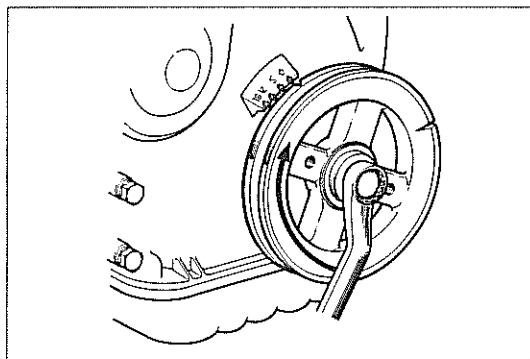

Set the No.1 cylinder to TDC/compression.

Fig. 5-125

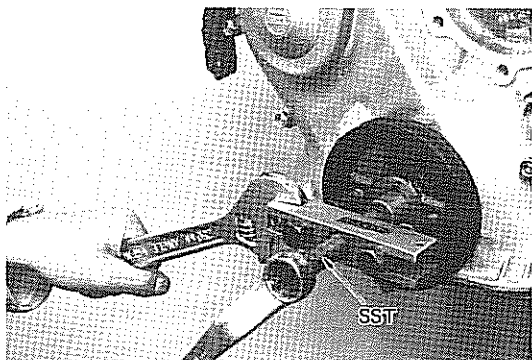

Remove the crankshaft pulley with SST.
SST[09213-31021]

Fig. 5-126

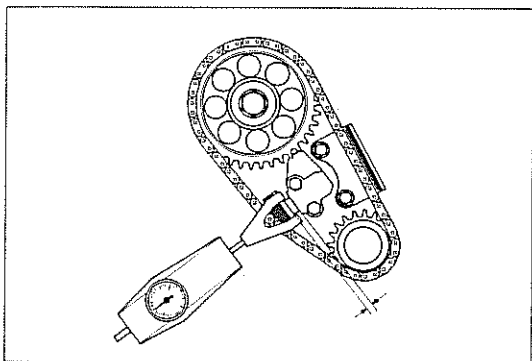

Check the chain slack.

Slack limit: 13.5 mm at 10 kg
(0.53 in.) (22 lb)

Fig. 5-127

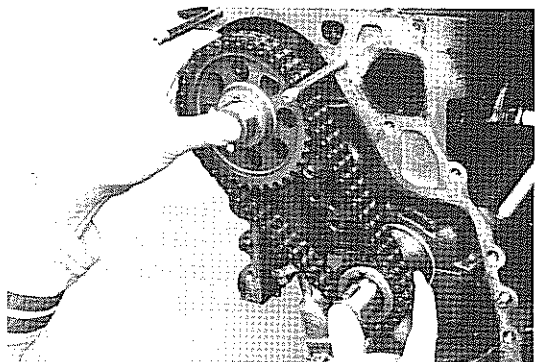

Pull out the two gears uniformly.

Fig. 5-128

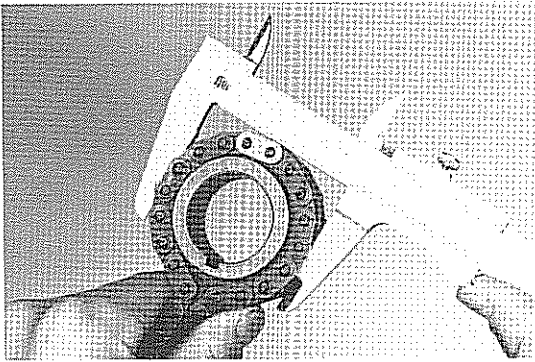

INSPECTION & REPAIR

Timing Gear & Chain

1. Inspect the gears and chains for cracks, wear or chipped teeth.
2. Measure the gear for wear in the method shown in the figure.

Fig. 5-129

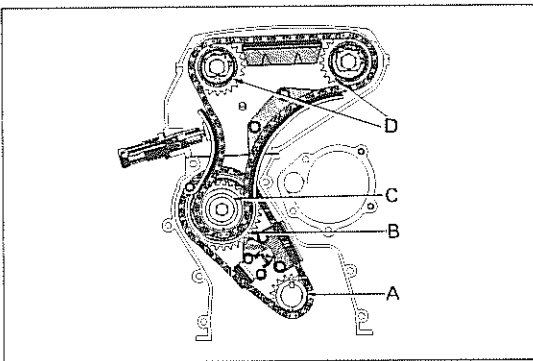

3. If measurement is below limit, replace the gears and chain.

Wear limit:

- A Crankshaft sprocket
60.0 mm (2.36 in.)
- B Pump drive shaft sprocket
114.5 mm (4.51 in.)
- C Camshaft drive sprocket
78.2 mm (3.08 in.)
- D Camshaft timing sprocket
78.2 mm (3.08 in.)

Fig. 5-130

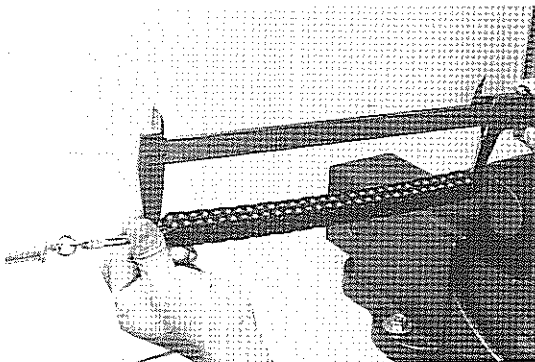

4. Measure the elongation of the No.1 timing chain.

Chain elongation:

- Limit 291.4 mm tension at 5 kg
(11.47 in.) (11 lb)

Fig. 5-131

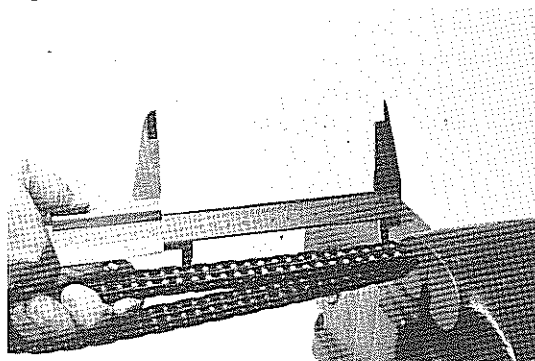

5. Measure the 17-link elongation of the No.2 timing chain. Replace the chain if over the elongation limit.

– Note –

Measure at 3 places and use the maximum measurement.

Chain elongation:

- Limit 147.0 mm tension at 17-links
(5.79 in.)

Fig. 5-132

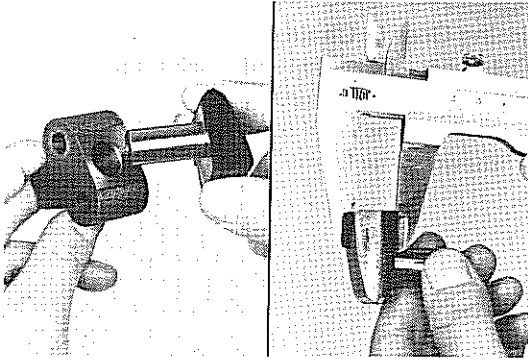

No.1 Chain Tensioner

Check the body and plunger for wear and measure the tensioner head as shown in the figure. If worn down over the limit, replace as a unit.

Thickness limit: 12.5 mm (0.49 in.)

Fig. 5-133

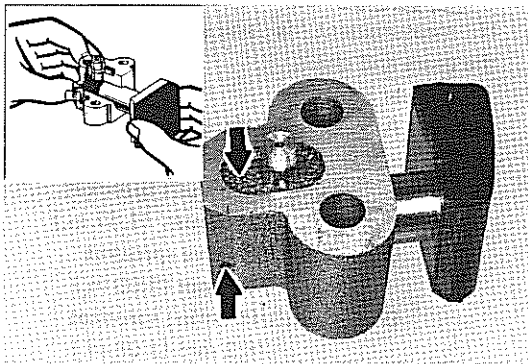

Inspect the chain tensioner No.1 for air tightness.

Fig. 5-134

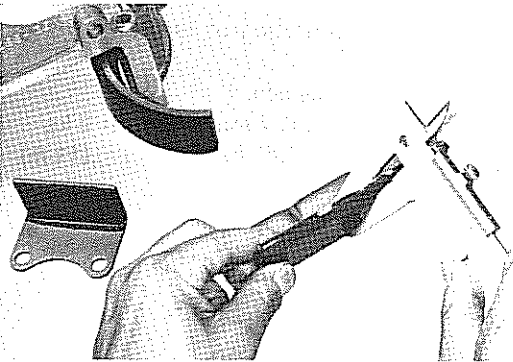

Chain Damper & Slipper

Measure each chain damper and check for wear. Take out the plunger spring. Coat the plunger with engine oil, close off the 2 oil orifices on the tensioner body and pull the plunger. If there is a return pulling force on the plunger, it is air tight.

Fig. 5-135

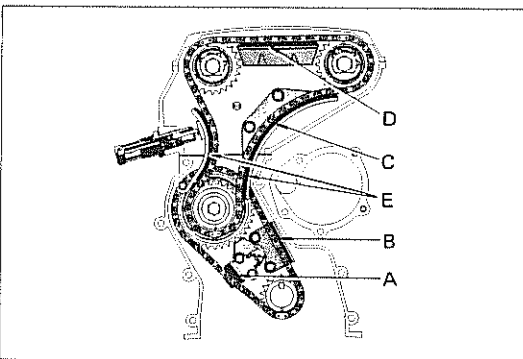

If either is visibly worn or measures less than limit, replace units.

Thickness limit:

A	No.1 chain tensioner	12.5 mm (0.49 in.)
B	No.1 chain damper	5.0 mm (0.20 in.)
C	No.3 chain damper	6.5 mm (0.26 in.)
D	No.2 chain damper	5.5 mm (0.22 in.)
E	Chain tensioner slipper	7.5 mm (0.30 in.)

Fig. 5-136

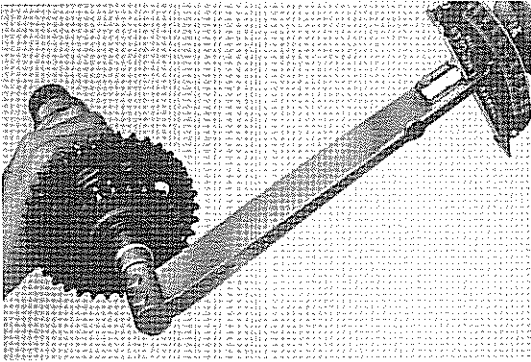

Timing Gear & Thrust Plate

Install the thrust plate, pump drive shaft gear and camshaft drive gear to the pump drive shaft. Tighten the camshaft drive gear set bolt.

Tightening torque: 7.0 – 8.0 kg-m
(51 – 57 ft-lb)

Fig. 5-137

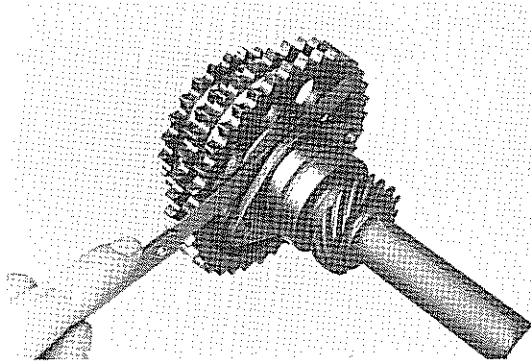

Measure the thrust clearance. If it exceeds limit, replace thrust plate.

Thrust clearance:

STD 0.07 – 0.15 mm
(0.003 – 0.006 in.)
Limit 0.3 mm
(0.01 in.)

Fig. 5-138

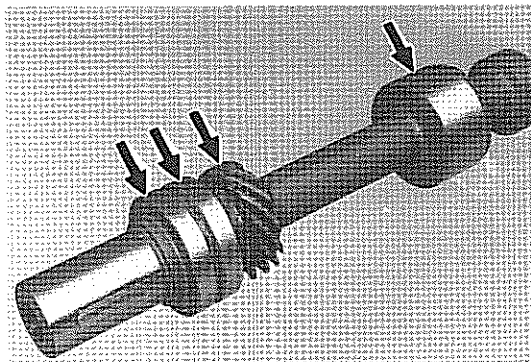

Pump Drive Shaft & Bearing

1. Inspect the gear and journal for cracks, wear or chipped teeth. If damaged, replace. Also inspect the distributor gear.

Fig. 5-139

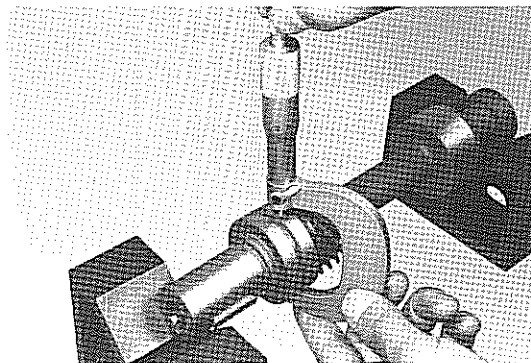

2. Measure oil clearance.
(1) Measure pump drive shaft journal.

Journal outer diameter:

No.1 46.459 – 46.475 mm
(1.8291 – 1.8297 in.)
No.2 46.209 – 46.225 mm
(1.8192 – 1.8199 in.)

Fig. 5-140

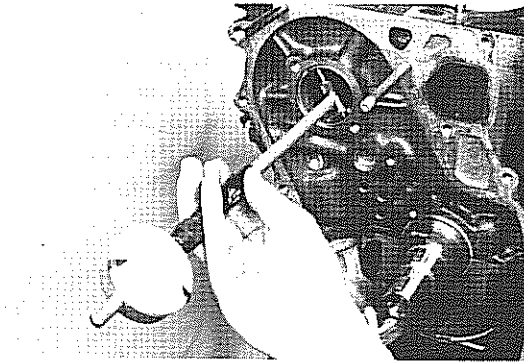

- (2) Measure the inner diameter of bearing.

Journal inner diameter:

No.1 46.500 – 46.525 mm
(1.8307 – 1.8317 in.)

No.2 46.250 – 46.275 mm
(1.8209 – 1.8218 in.)

Oil clearance:

STD 0.025 – 0.066 mm
(0.0010 – 0.0026 in.)

Limit 0.08 mm
(0.003 in.)

Fig. 5-141

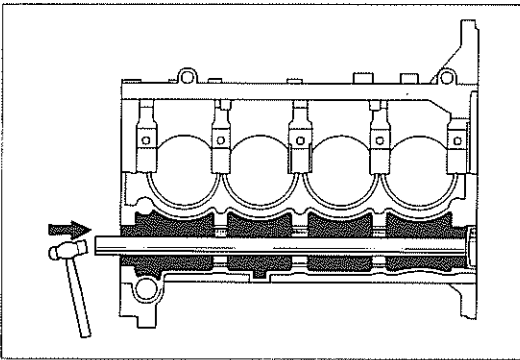

3. Bearing replacement.

- (1) Drive out the plug from the cylinder block.

Fig. 5-142

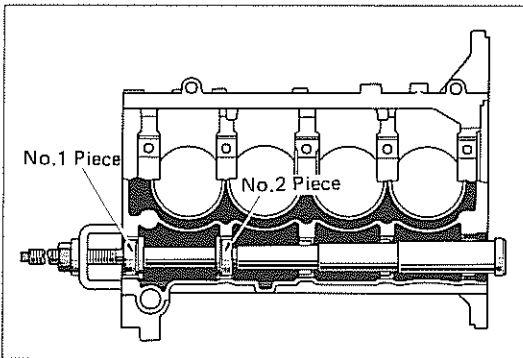

- (2) Remove the No.1 bearing with SST.
SST[09215-25010]

– Note –

Use the No.2 piece as a guide.

Fig. 5-143

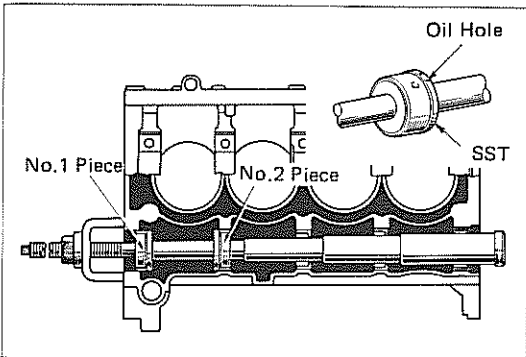

- (3) Install the No.1 bearing.

– Note –

1. Use the No.2 piece as a guide.
2. Align the bearing oil hole.

Fig. 5-144

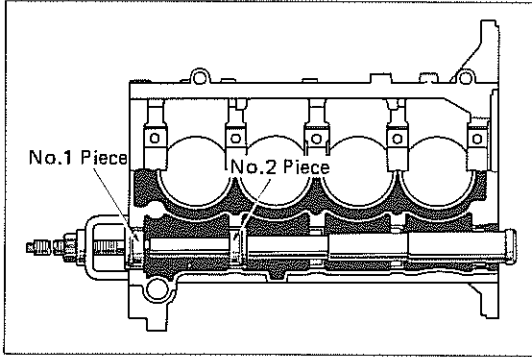

(4) Remove the No.2 bearing.

– Note –

Use the No.1 piece as a guide.

Fig. 5-145

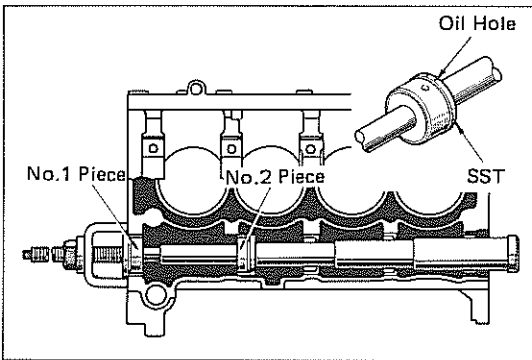

(5) Install the No.2 bearing.

– Note –

1. Use the No.1 piece as a guide.
2. Align the bearing oil hole.

Fig. 5-146

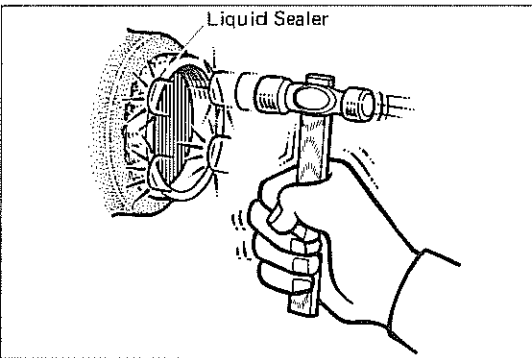

(6) Apply sealer to the new plug and install.

Fig. 5-147

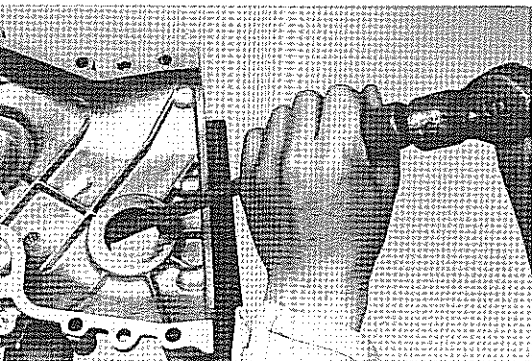

Crankshaft Front Oil Seal

1. Inspect the oil seal lip for wear or deformation. Also inspect the crankshaft.
2. Oil seal replacement.
 - (1) Remove oil seal with a screwdriver.

Fig. 5-148

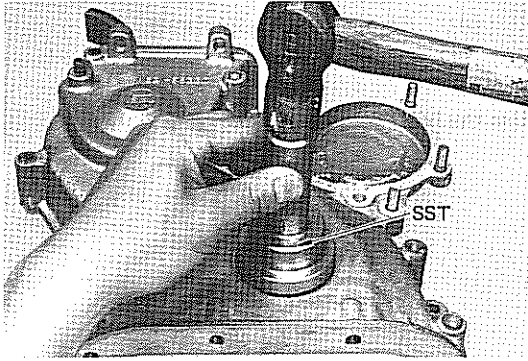

- (2) Install a new oil seal as shown in the figure.
SST [09223-22010]

Fig. 5-149

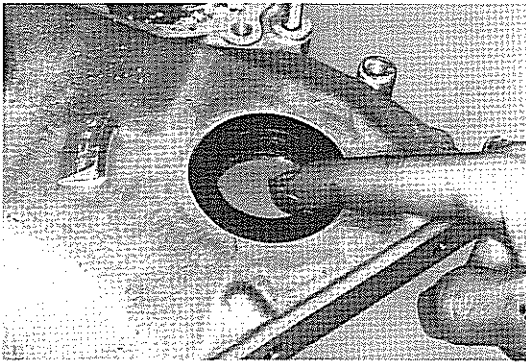

- (3) After driving in the seal, coat the seal lip lightly with MP grease.

ASSEMBLY

Assemble the parts in the numerical order shown in the figure.

Fig. 5-150

- Thoroughly clean the parts to be assembled.
- Apply clean engine oil on the sliding and rotating surfaces of the parts before assembly.

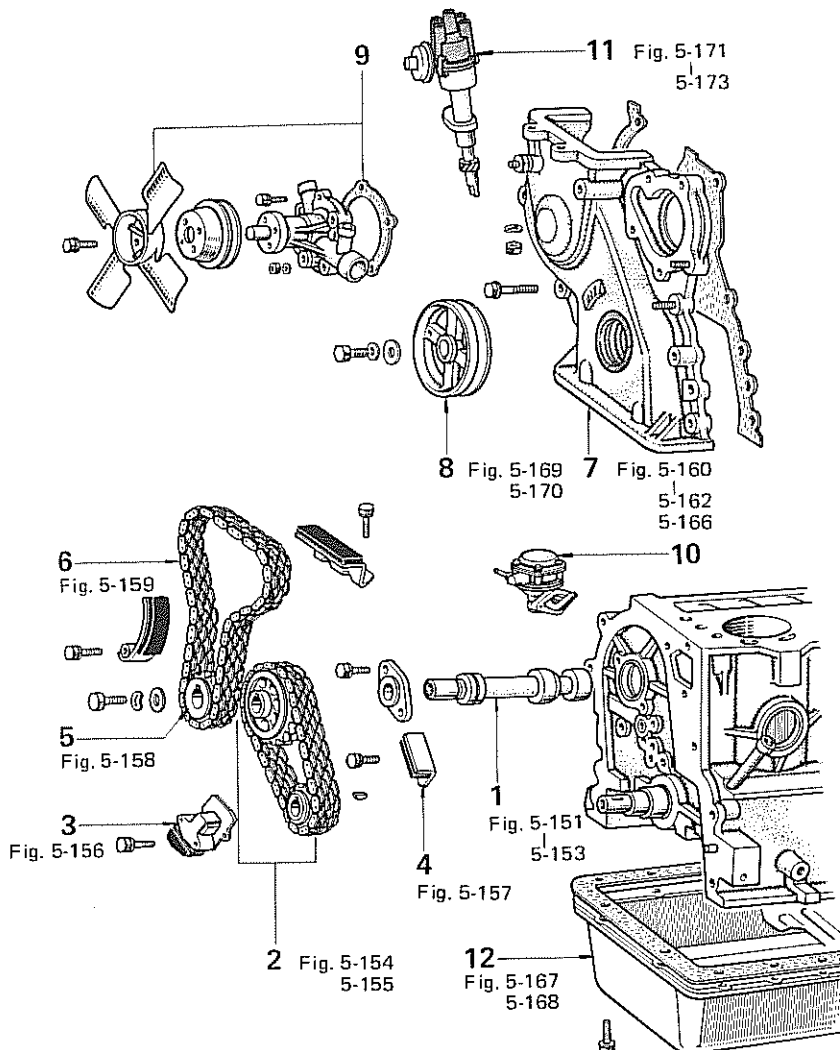

- | | | |
|-----------------------------|------------------------|---------------------|
| 1. Pump Drive Shaft | 5. Camshaft Drive Gear | 9. Water Pump & Fan |
| 2. No.1 Timing Chain & Gear | 6. No.2 Timing Chain | 10. Fuel Pump |
| 3. No.1 Chain Tensioner | 7. Timing Gear Cover | 11. Distributor |
| 4. No.1 Chain Damper | 8. Crankshaft Pulley | 12. Oil Pan |

Fig. 5-151

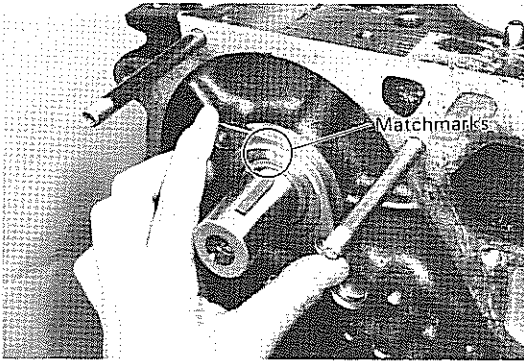

Install the pump drive shaft thrust plate.

Tightening torque: 1.5 – 2.1 kg-m
(11 – 15 ft-lb)

– Note –

Face the side of the thrust plate with the mark outwards.

Fig. 5-152

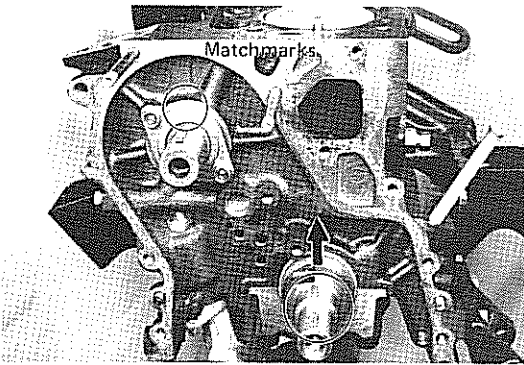

Set the crankshaft keyway upwards. Align the pump drive shaft key with the thrust plate mark.

Fig. 5-153

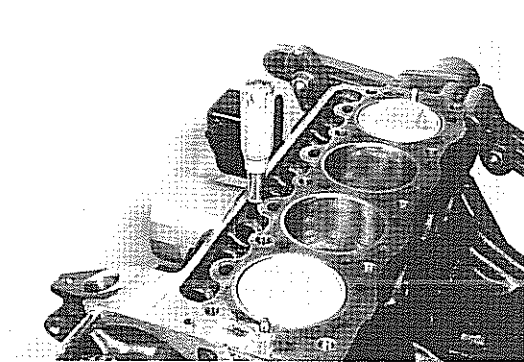

Insert a screwdriver in back of the pump drive shaft so that it will not completely enter.

Fig. 5-154

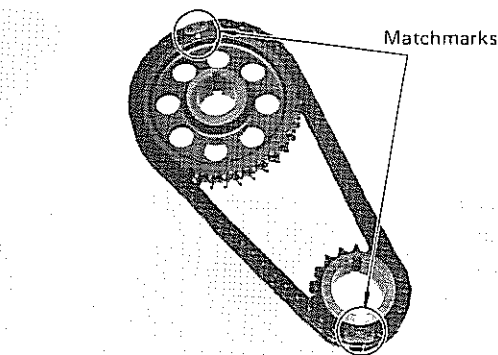

Assemble the crankshaft gear and pump drive shaft gear to the No.1 chain so that their respective matchmarks are aligned.

Fig. 5-155

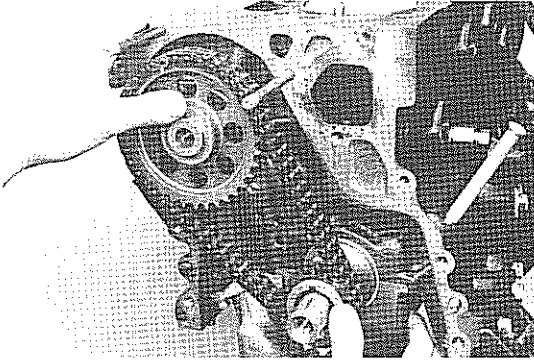

Drive in the two gears simultaneously to the shafts.

Fig. 5-156

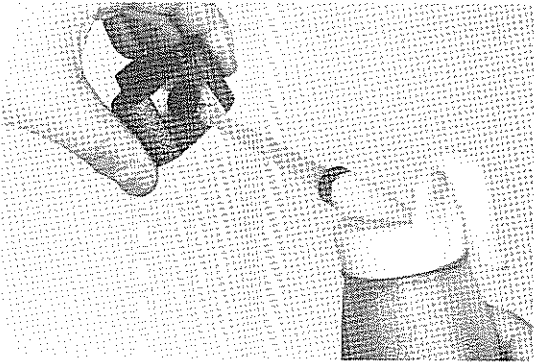

Insert oil into the No.1 chain tensioner cylinder.

Fig. 5-157

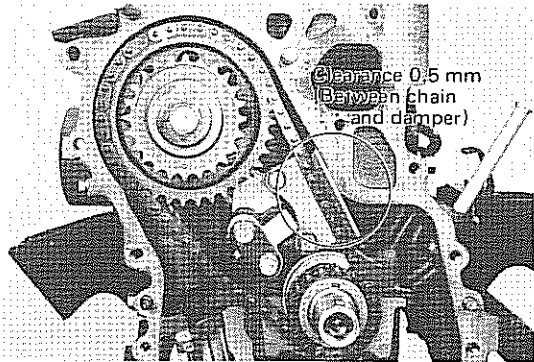

Install the chain damper parallel with the chain at a 0.5 mm (0.02 in.) space between them.

Fig. 5-158

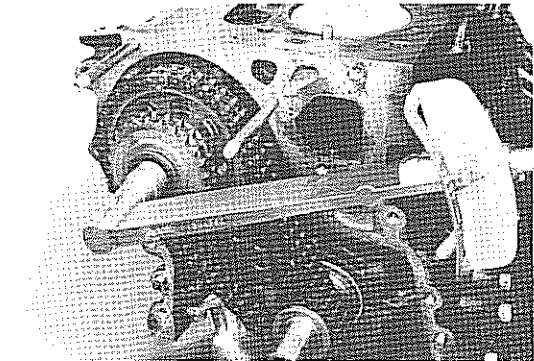

Tighten the camshaft drive gear set bolt.
Tightening torque: **6.0 – 7.0 kg-m**
(44 – 50 ft-lb)

Fig. 5-159

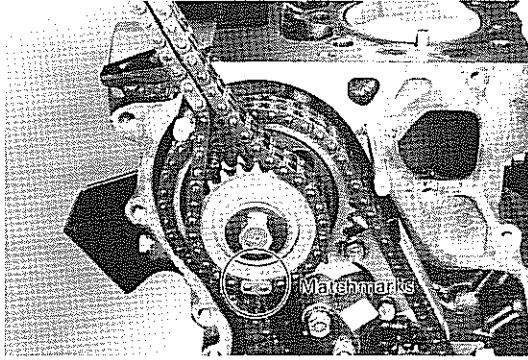

Align the No.2 chain and gear matchmarks and install.

Fig. 5-160



Pull No.2 chain and install the chain cover.

Fig. 5-161

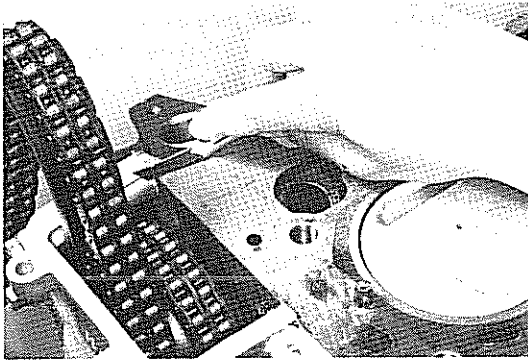

Cutoff any portion of the gasket protruding from the cylinder block upper surface.

Fig. 5-162

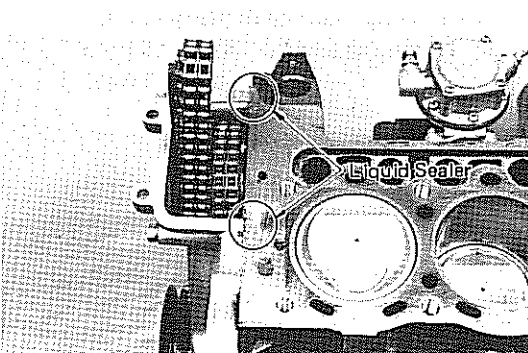

Apply liquid sealer as shown in the figure.

Fig. 5-163

SEE
CYLINDER HEAD
ASSEMBLY SECTION
Fig. 5-67 to 5-79

Install the cylinder head.

Fig. 5-164

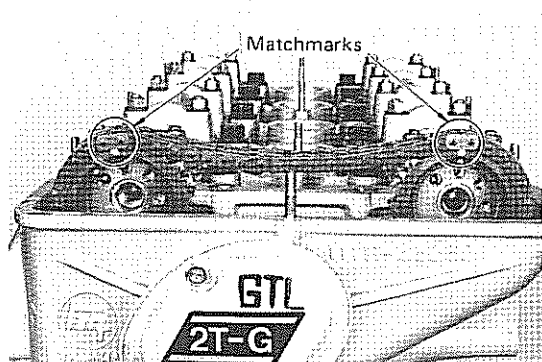

Install the sprocket and chain aligned with the chain and gear marks.

Fig. 5-165

SEE
CYLINDER HEAD
ASSEMBLY SECTION
Fig. 5-106 to 5-120

Adjust the valve timing.

Fig. 5-166



Cutoff any portion of the gasket protruding from the cylinder block lower surface.

Fig. 5-167

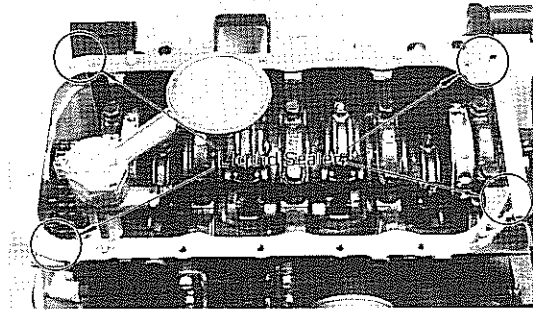

Apply sealer to the areas indicated in the figure.

Fig. 5-168

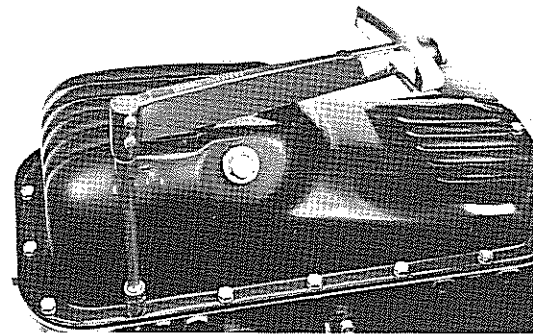

Install the oil pan.

Tightening torque: 0.4 – 0.8 kg-m
(3 – 5 ft-lb)

Fig. 5-169

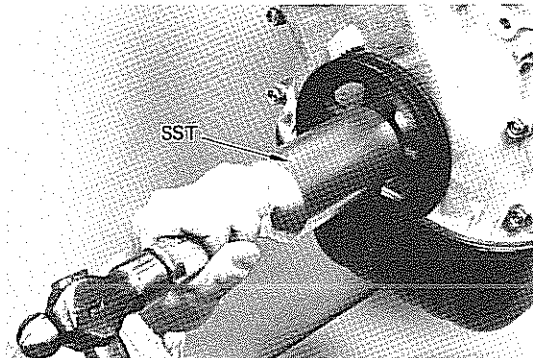

Drive in the crankshaft pulley with SST.
SST[09214-60010]

Fig. 5-170

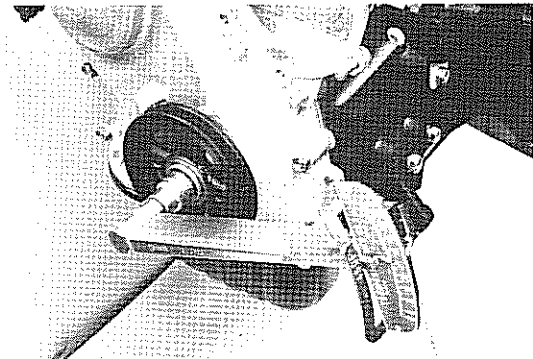

Tighten the claw nut.

Tightening torque: 6.0 – 7.0 kg-m
(44 – 50 ft-lb)

Fig. 5-171

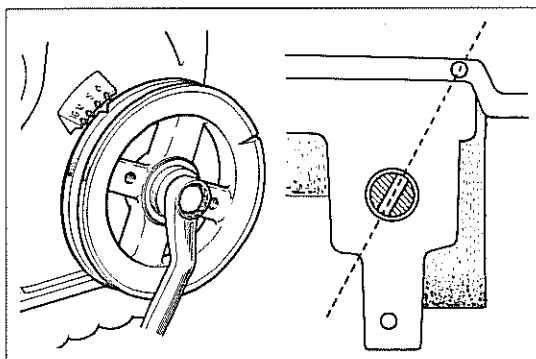

Install the distributor as follow.

1. Set the No.1 cylinder to 5° BTDC/compression.
2. Set the oil pump shaft slit as shown in the figure.

Fig. 5-172

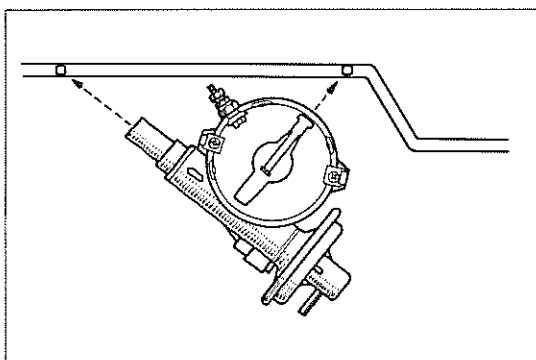

3. Before inserting the distributor, position the rotor and diaphragm as shown in the figure.

Fig. 5-173

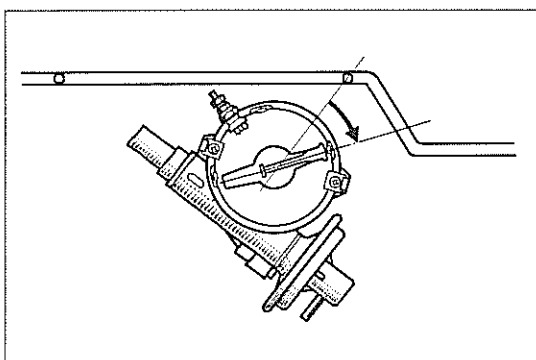

4. When fully installed, the rotor should point in the direction shown in the figure.



– Note –

Turn the distributor housing and adjust to the position just before the points open.

MEMO
