

CHARGING SYSTEM

	Page
CHARGING SYSTEM CIRCUIT	11-2
ON-VEHICLE INSPECTION	11-4
ALTERNATOR	11-10
ALTERNATOR REGULATOR	11-35

CHARGING SYSTEM CIRCUIT

Fig. 11-1

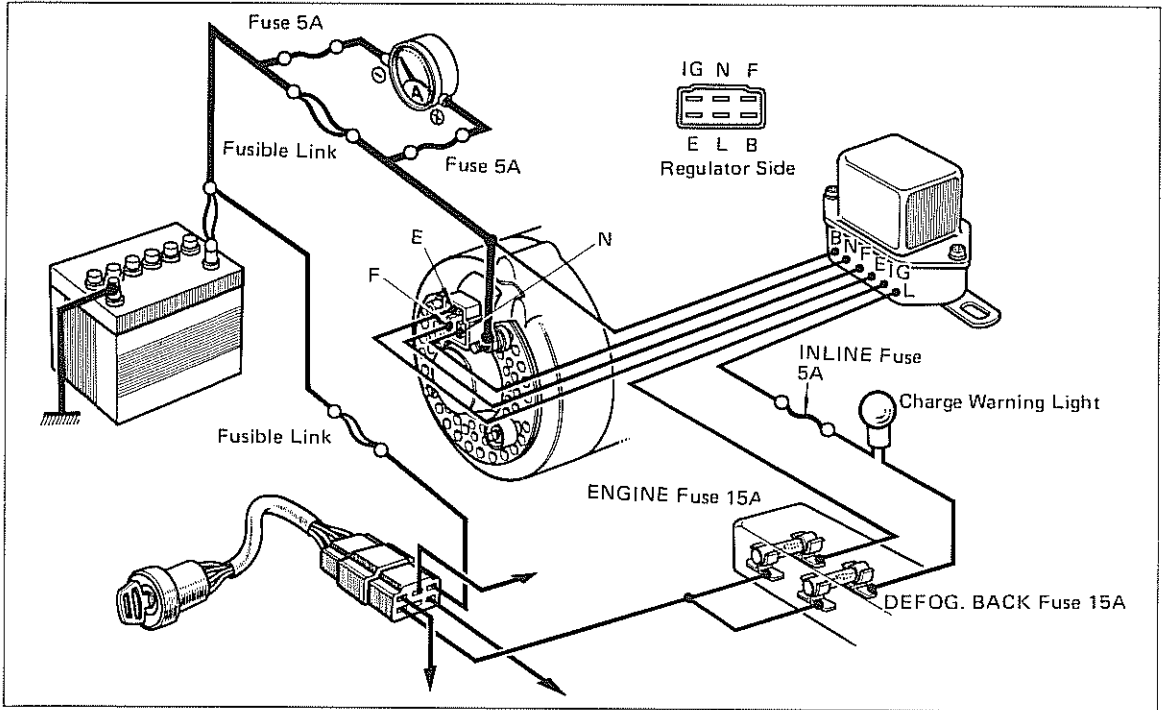
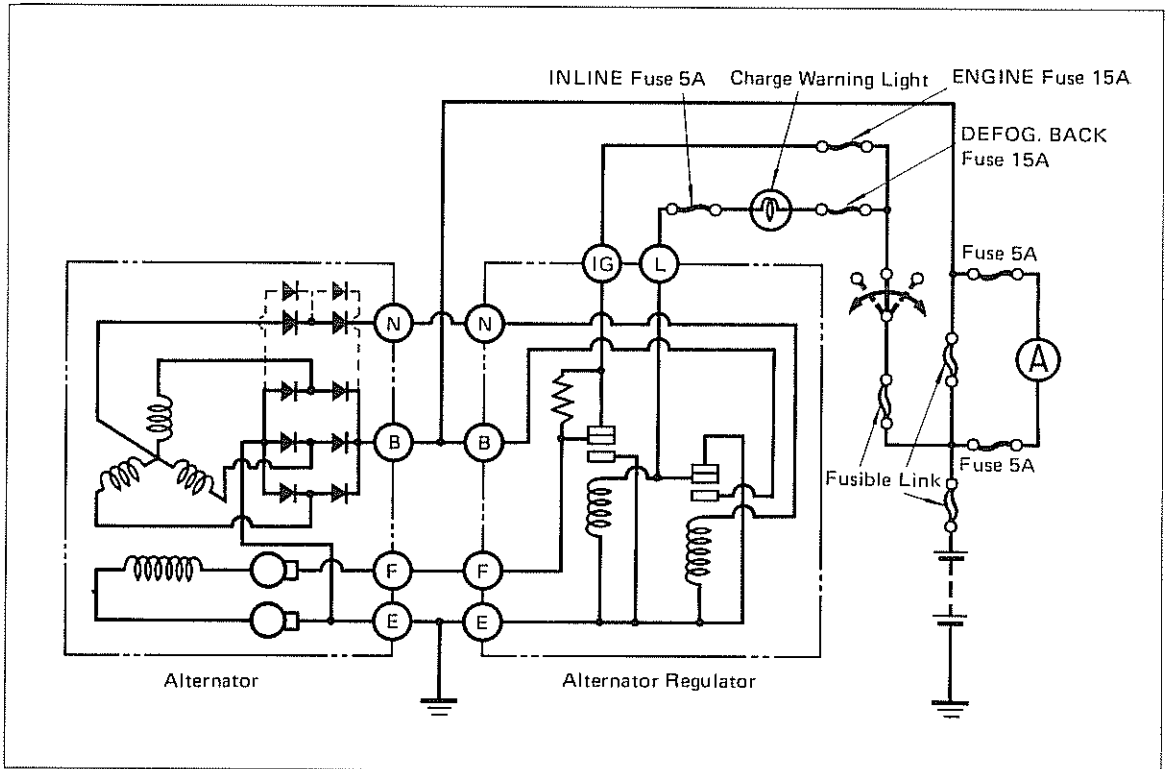

Fig. 11-2



FOR ALTERNATOR WITH IC REGULATOR

Fig. 11-3

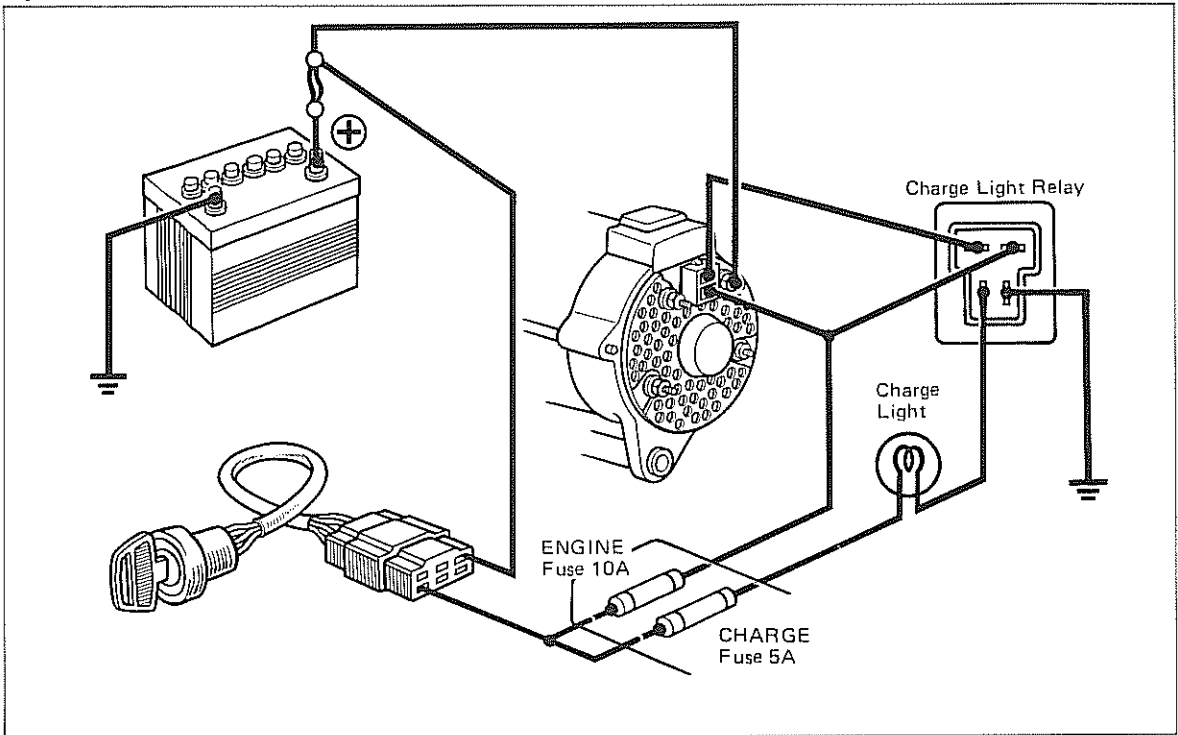

Fig. 11-4

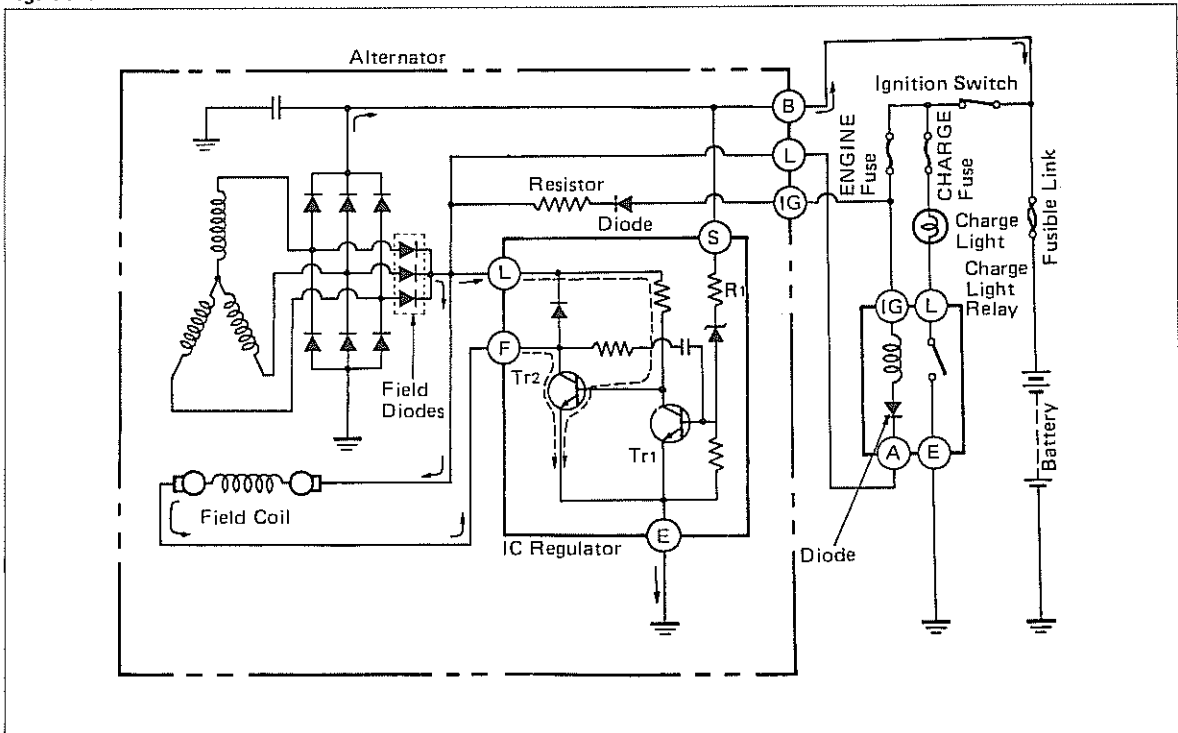
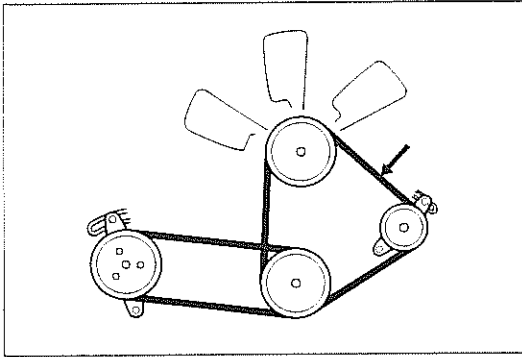

Fig. 11-5



ON-VEHICLE INSPECTION



1. Inspect the following system components:
Drive belt tension at 10 kg (22 lb):
 8 – 12 mm
 (0.3 – 0.5 in.)

Fig. 11-6

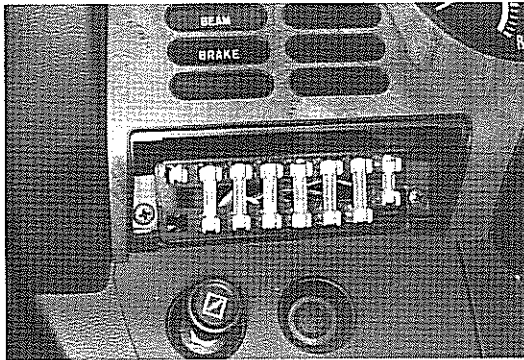

2. Fuses
 ENGINE fuse 15A
 GAUGE fuse 15A

Fig. 11-7

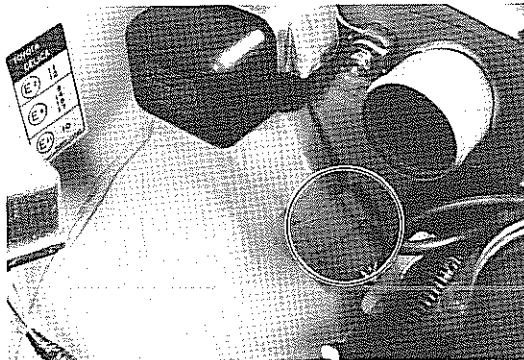

3. Installed condition of wiring for alternator and regulator.

Fig. 11-8

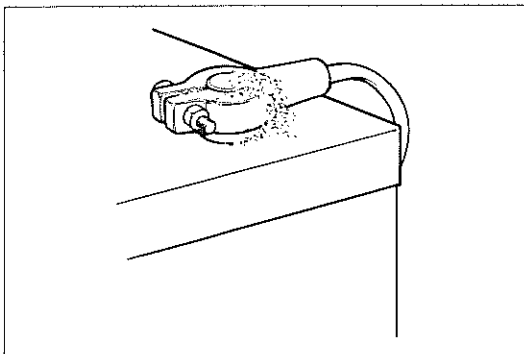

4. Battery terminal and fusible link
 Loose
 Corroded
 Burnt

Fig. 11-9

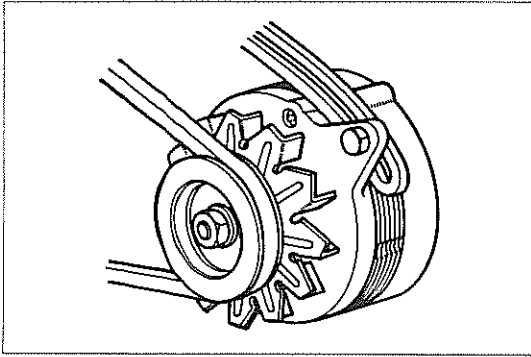

5. Alternator on-vehicle condition
Abnormal noise from alternator when engine is running.

Fig. 11-10

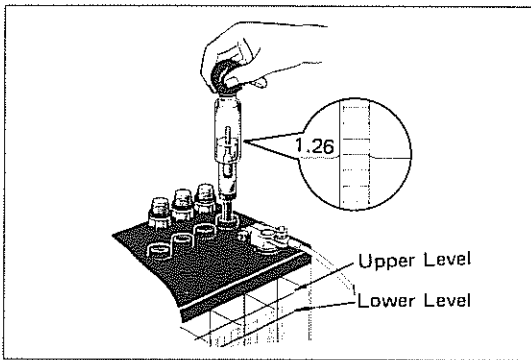

6. Specific gravity 1.25 – 1.27
Connect the voltmeter and ammeter as shown in the figure.

Fig. 11-11

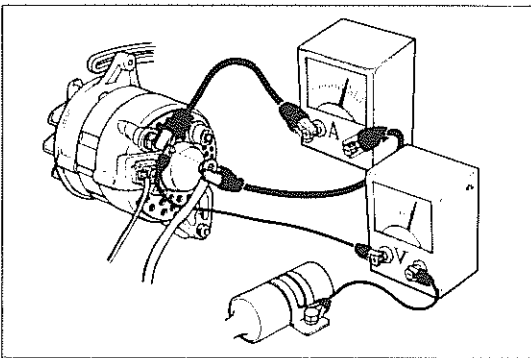

PERFORMANCE TEST USING VOLT-METER & AMMETER

1. Disconnect the wire from terminal B of the alternator and connect the wire to the negative terminal of the ammeter.
2. Connect the test lead from the positive terminal of the ammeter to terminal B of the alternator.
3. Connect the positive lead of the voltmeter to terminal B of the alternator.
4. Connect the negative lead of the voltmeter to ground.

Fig. 11-12

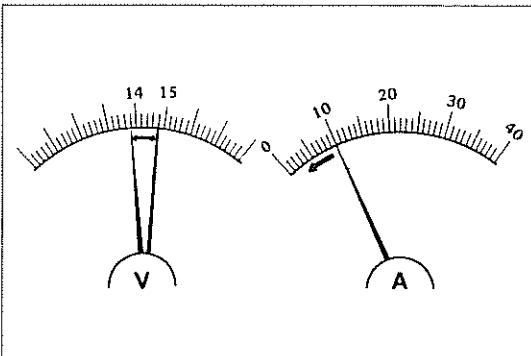

– Note –
Be careful not to cause a short.

No-load Performance Test

- Regulated voltage: 13.8 – 14.8V
- Current: Less than 10A
- Engine speed: Idling to 2,000 rpm

Fig. 11-13

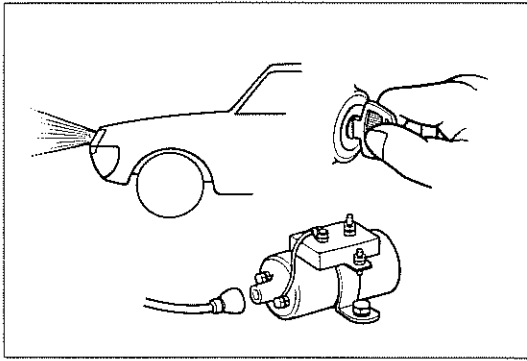

Load Performance Test

1. Crank the engine with ignition coil high tension cord disconnected for about 5 to 10 seconds.
2. Turn on headlights and accessories.

Fig. 11-14

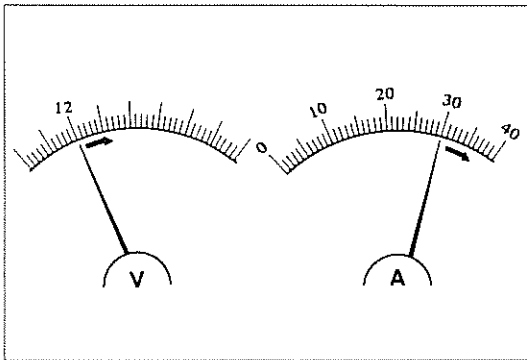

3. Start engine, and run it at approximately 2,000 rpm.

Regulated voltage: 12V
Current: More than 30A

Fig. 11-15

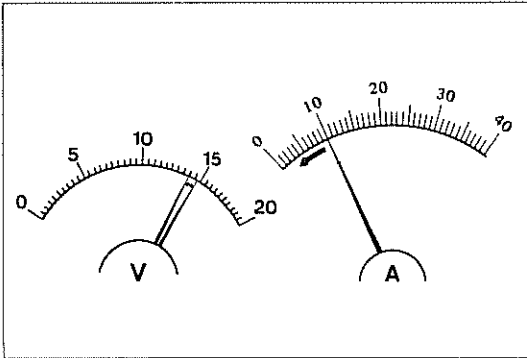

WITH IC REGURATOR TYPE

No-load Performance Test

Regulated voltage: 14.0 – 14.7V
Current: Less than 10A
Engine speed: Idling to 2,000 rpm

Fig. 11-16

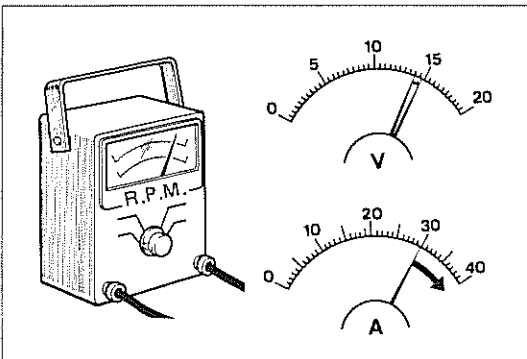

Load Performance Test

1. Run engine at 2,000 rpm.
2. Turn on headlights and all accessories.

Regulated voltage: 14.0 – 14.7V
Current: More than 30 A

Fig. 11-17

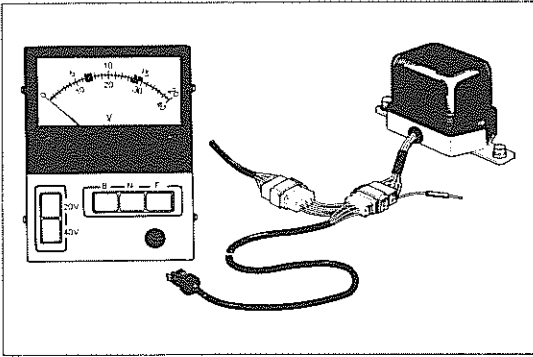

PERFORMANCE TEST BY ALTERNATOR CHECKER

SST [09081-00011]

1. Unplug the alternator regulator connector and plug in the checker connector.

Push 20V switch.

Fig. 11-18

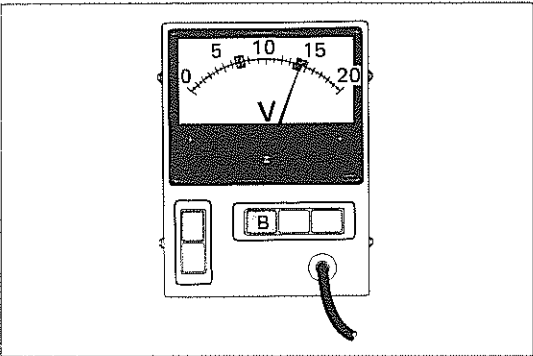

2. Check B terminal voltage.

Push B switch.

Raise engine speed from idling to 2,000 rpm.

Standard voltage: 13.8 – 14.8V

If not within standard, probable cause is the alternator regulator.

Fig. 11-19

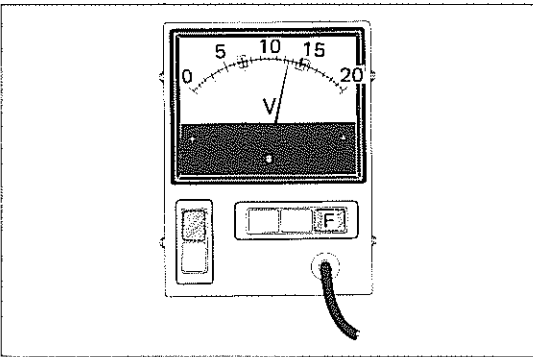

3. Check F terminal voltage.

Push F switch.

Gradually raise engine speed. The checker reading should gradually decrease from 12 to 3 volts.

If decrease is not registered, probable cause is alternator regulator.

Fig. 11-20

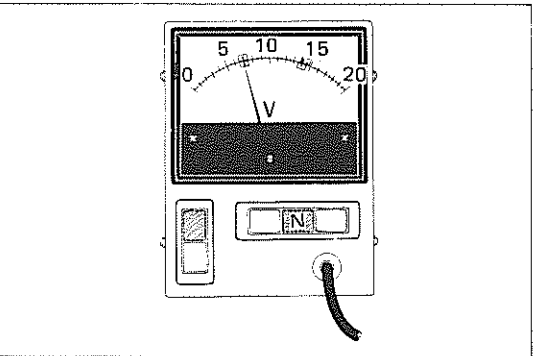

4. Check N terminal voltage.

Push N switch.

Maintain engine speed at approximately 1,500 rpm. The pointer should be at a half of B terminal voltage.

Standard voltage: 6.9 – 7.4V

If the voltage is higher, the cause will be (+) rectifier.

If the voltage is lower, the cause will be (-) rectifier.

Fig. 11-21

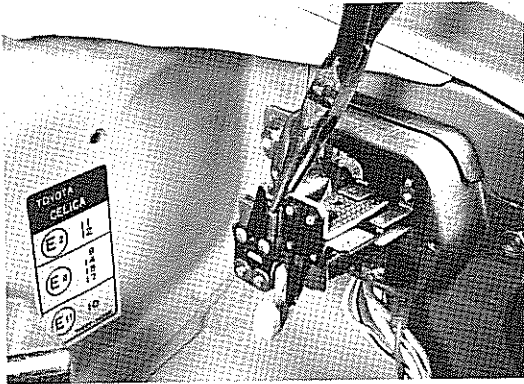

ADJUST OUTPUT VOLTAGE

If not within the output voltage, adjust by bending the adjusting arm.

Voltage: 13.8 – 14.8V

Engine speed: Idling to 2,000 rpm

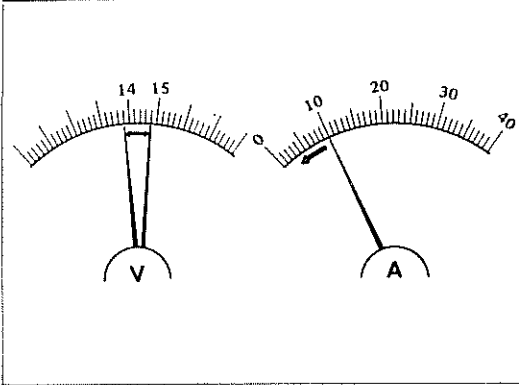
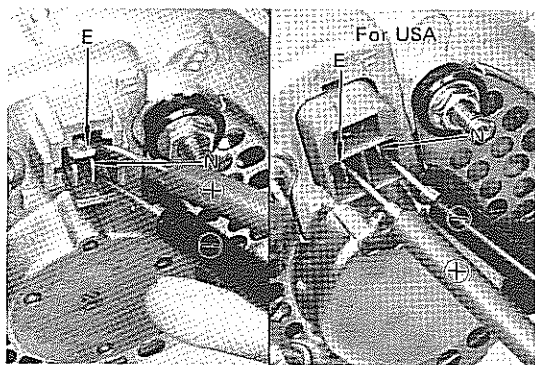

Fig. 11-22



ALTERNATOR INSPECTION

1. Negative side rectifier short test.
Connect an ohmmeter (-) lead to N terminal and (+) lead to E terminal.
Meter should indicate infinity.

Fig. 11-23

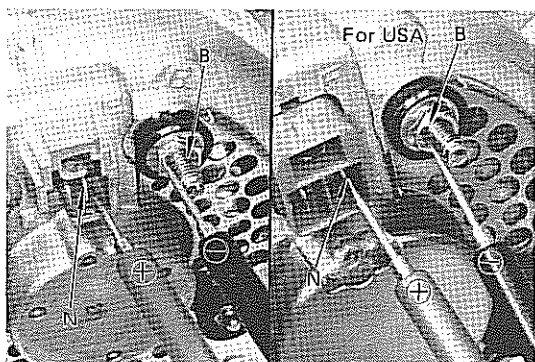

2. Positive side rectifier short test.
Connect an ohmmeter (-) lead to B terminal and (+) lead to N terminal.
Meter should indicate infinity.

Fig. 11-24

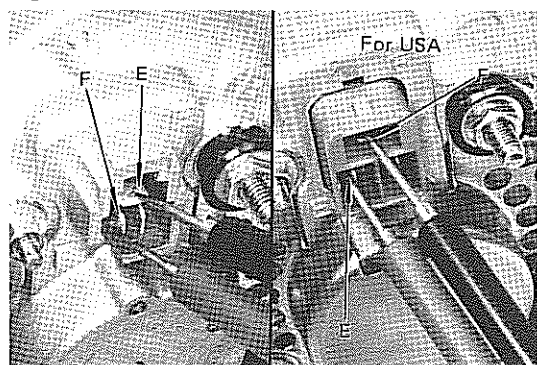

3. Check rotor coil resistance.
Resistance: 5 – 9 Ω

Fig. 11-25

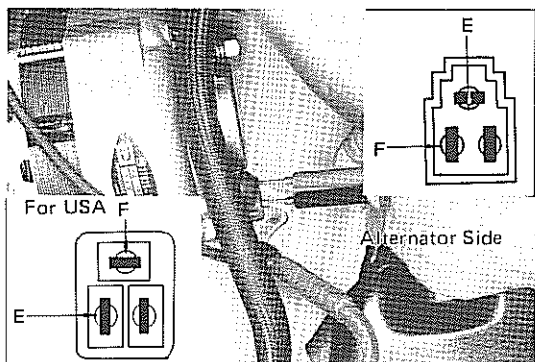

4. Turn the ignition switch to ON position, and check to see if there is battery voltage at F terminal. If not, check the ENGINE fuse.

ALTERNATOR CUTAWAY VIEW

Fig. 11-26

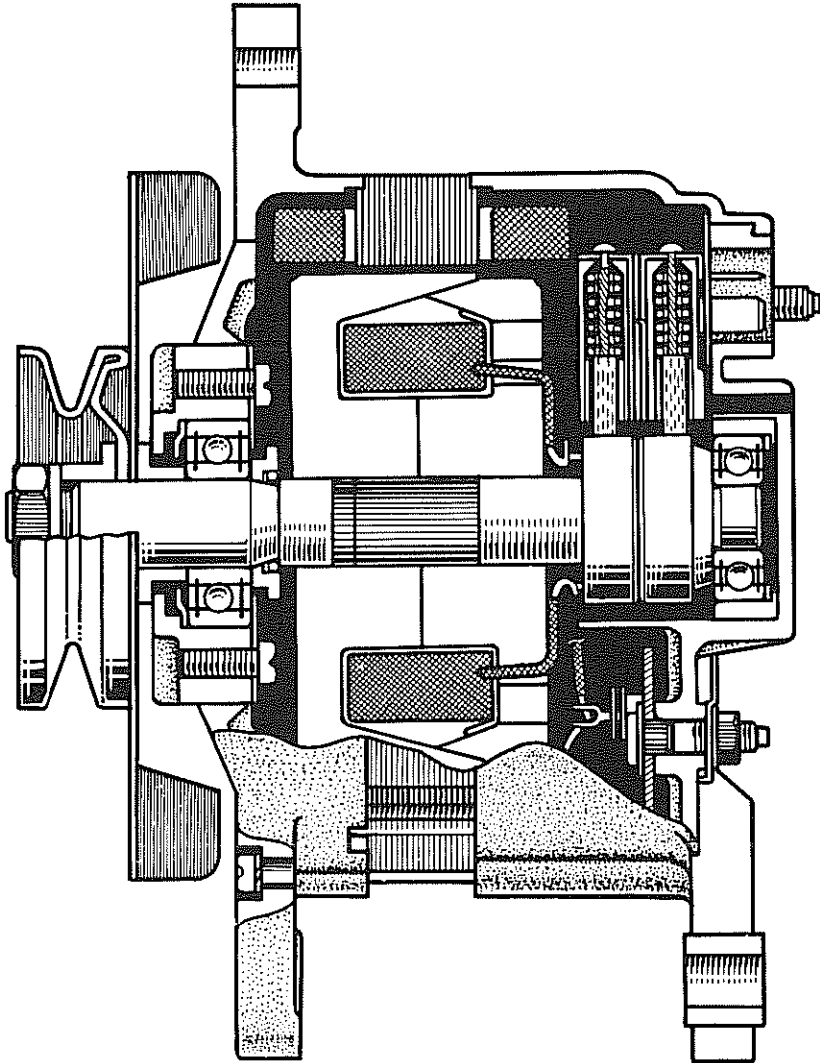
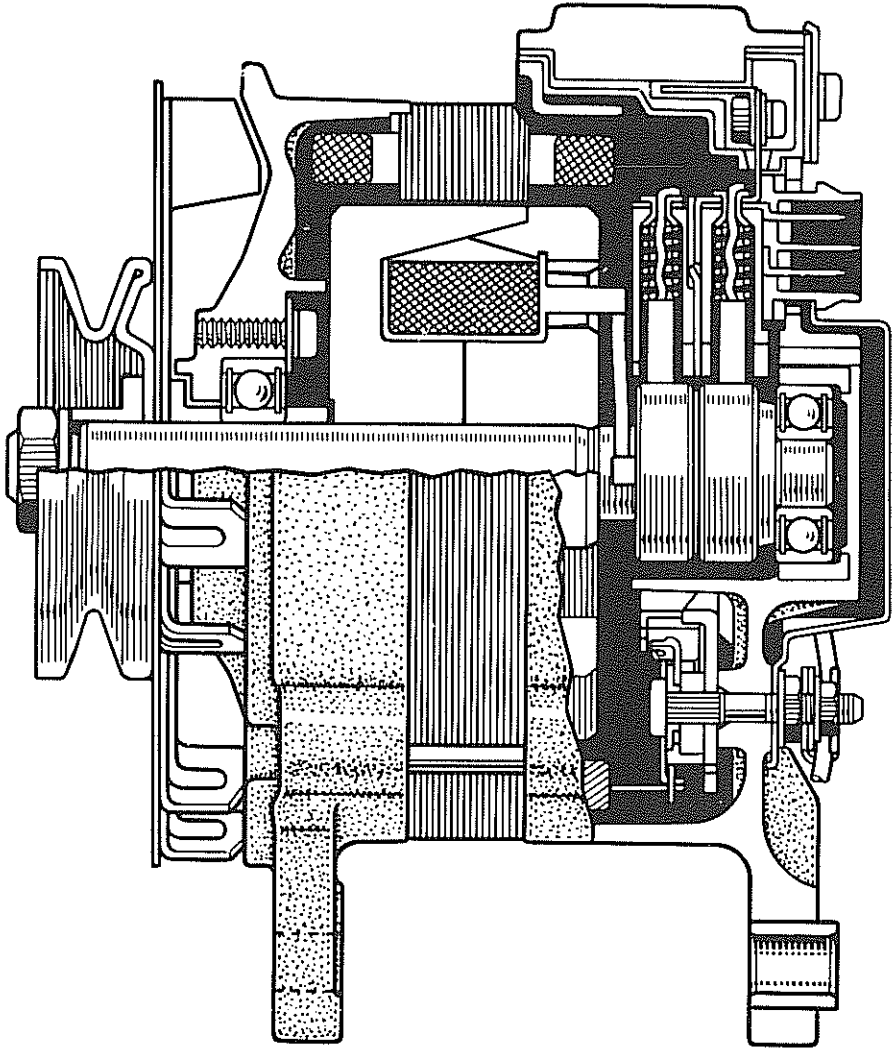

Fig. 11-27

For ALTERNATOR WITH IC REGULATOR



DISASSEMBLY

Disassemble the parts in the numerical order shown in the figure.

Fig. 11-28

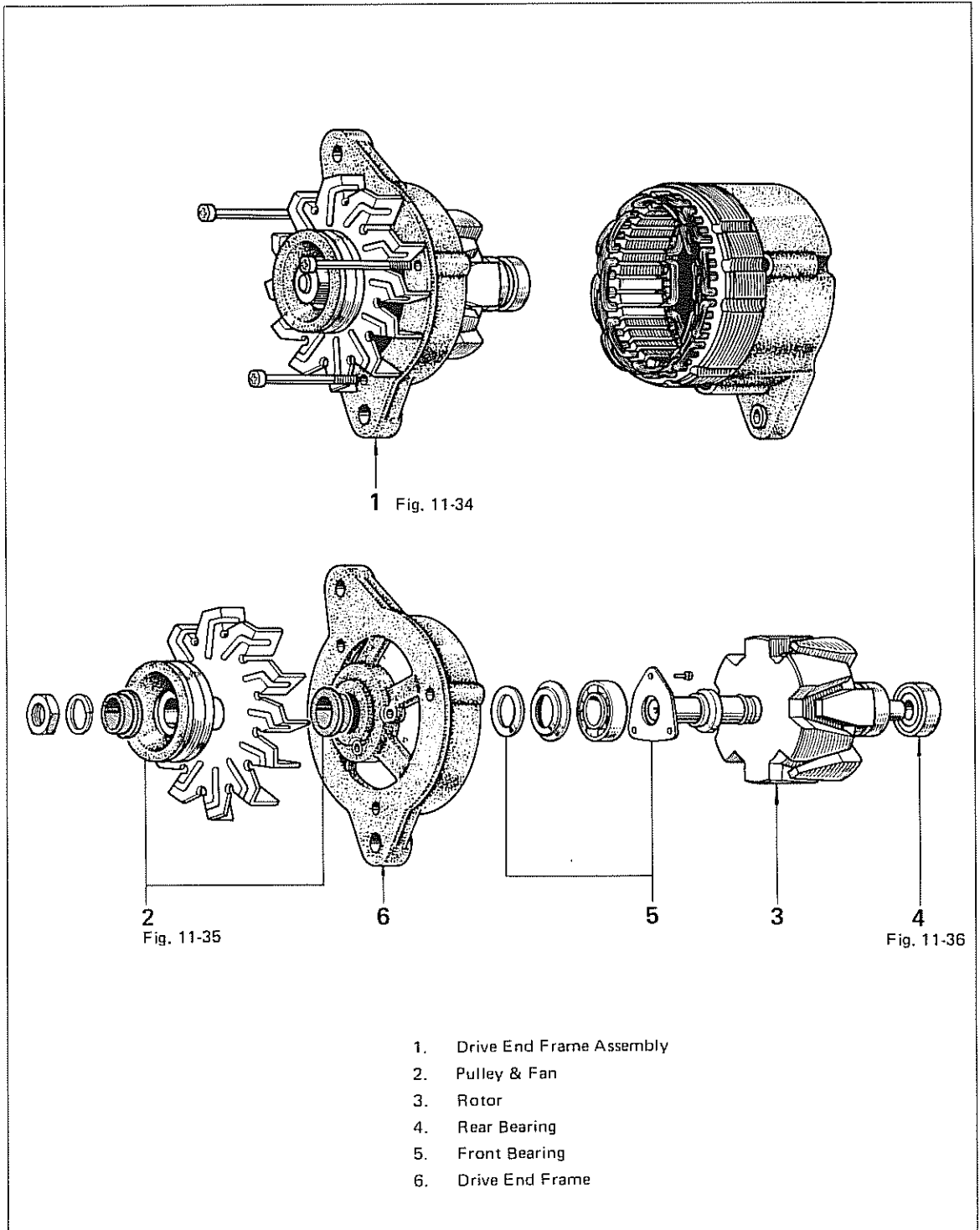

Disassemble the parts in the numerical order shown in the figure.

Fig. 11-29

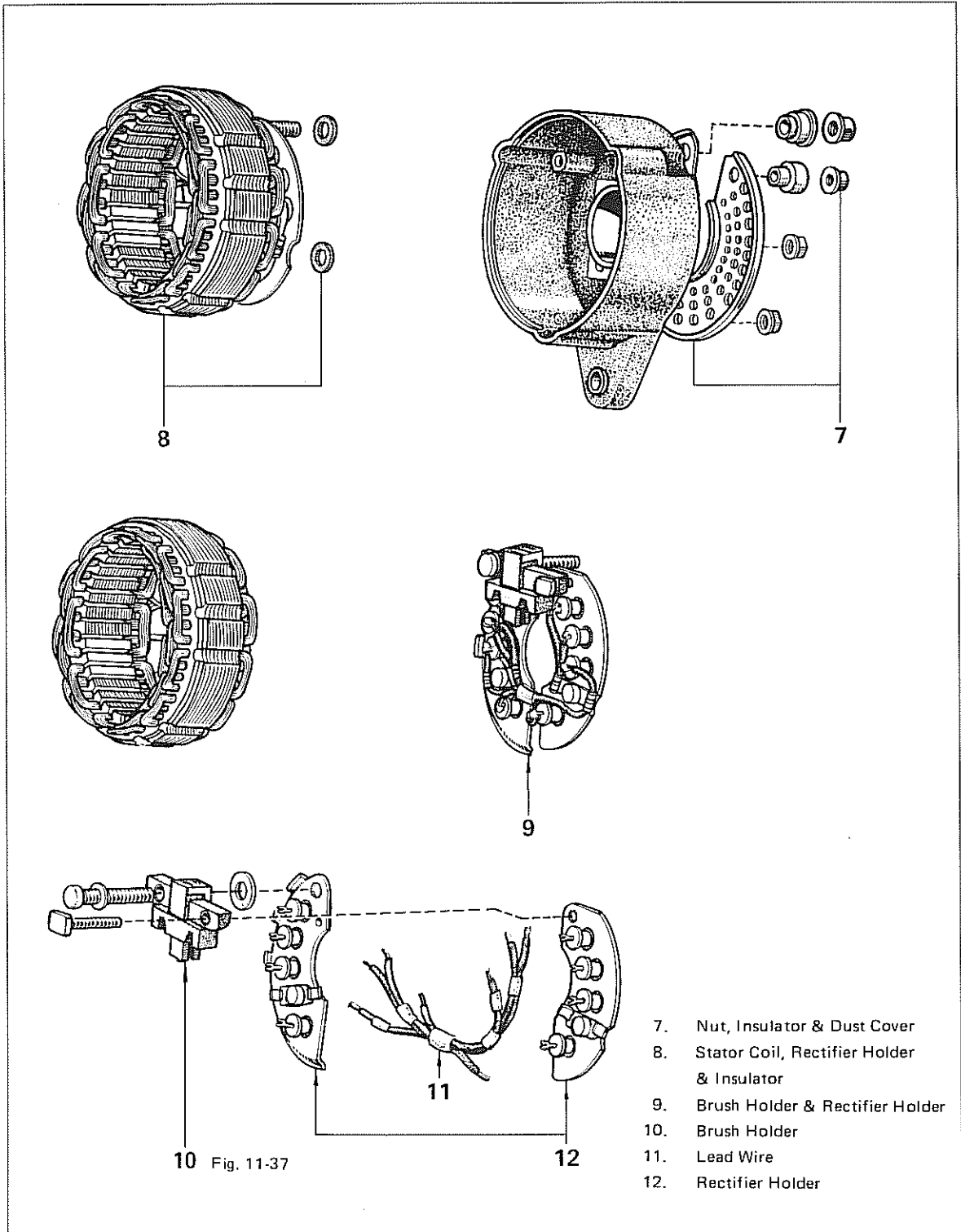

10 Fig. 11-37

- 7. Nut, Insulator & Dust Cover
- 8. Stator Coil, Rectifier Holder & Insulator
- 9. Brush Holder & Rectifier Holder
- 10. Brush Holder
- 11. Lead Wire
- 12. Rectifier Holder

Disassemble the parts in the numerical order shown in the figure.

Fig. 11-30

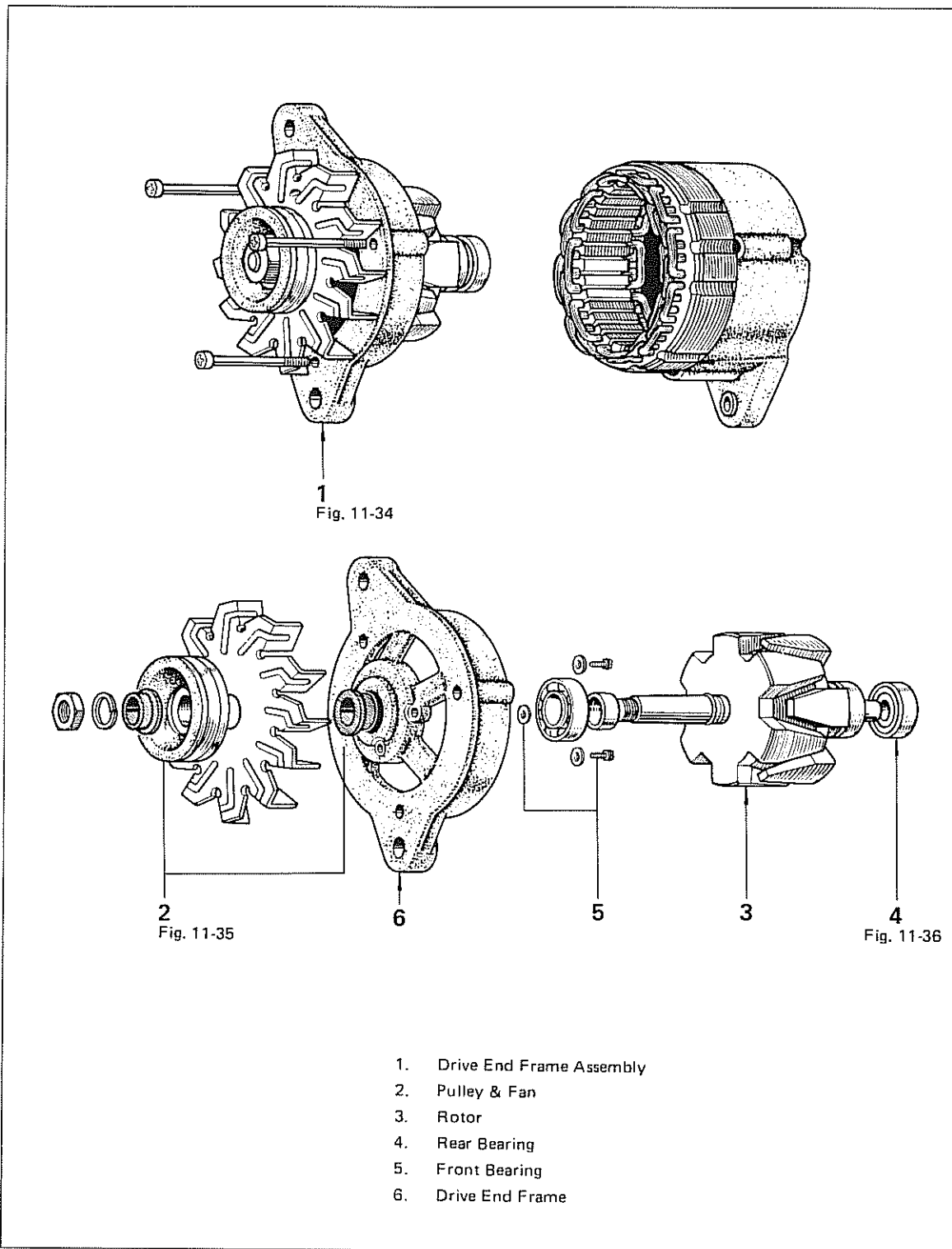

1. Drive End Frame Assembly
2. Pulley & Fan
3. Rotor
4. Rear Bearing
5. Front Bearing
6. Drive End Frame

Disassemble the parts in the numerical order shown in the figure.

Fig. 11-31

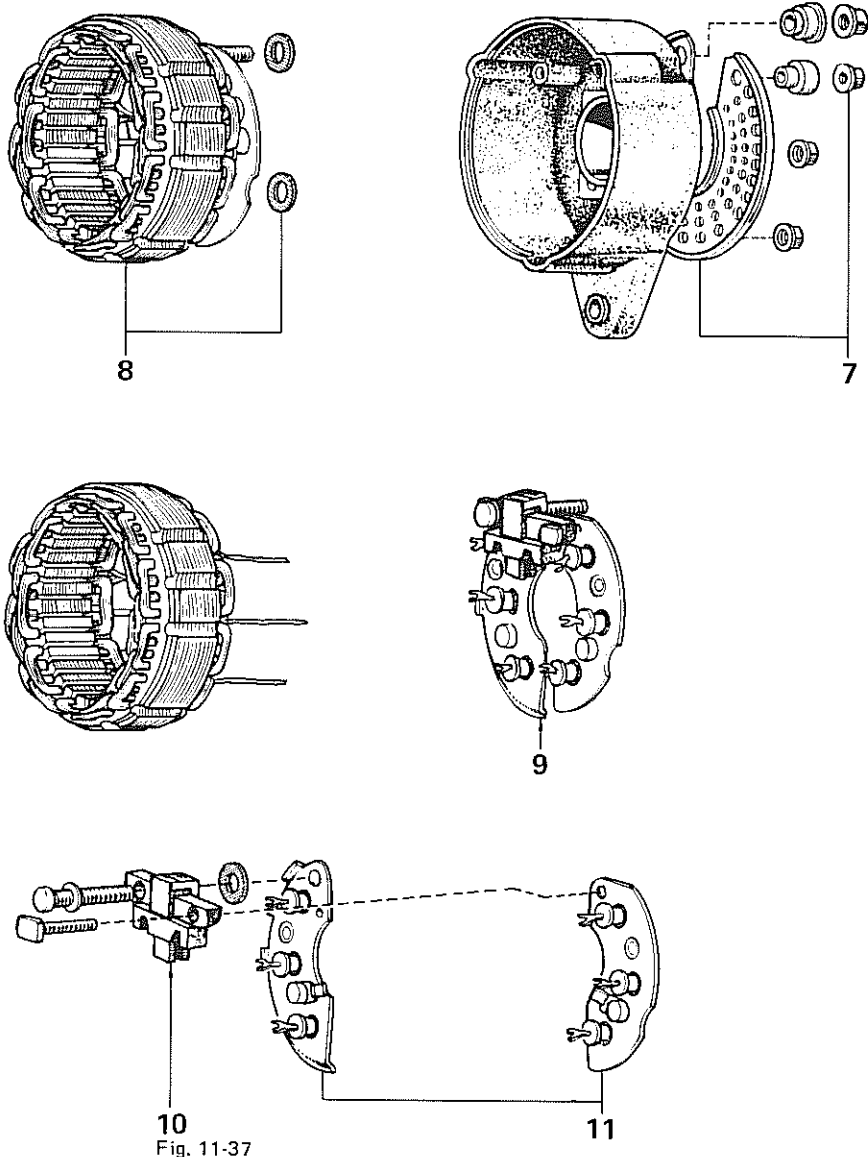

Fig. 11-37

- 7. Nut, Insulator & Dust Cover
- 8. Stator Coil, Rectifier Holder & Insulator
- 9. Brush Holder & Rectifier Holder
- 10. Brush Holder
- 11. Rectifier Holder

For Alternator with IC Regulator

Disassemble the parts in the numerical order shown in the figure.

Fig. 11-32

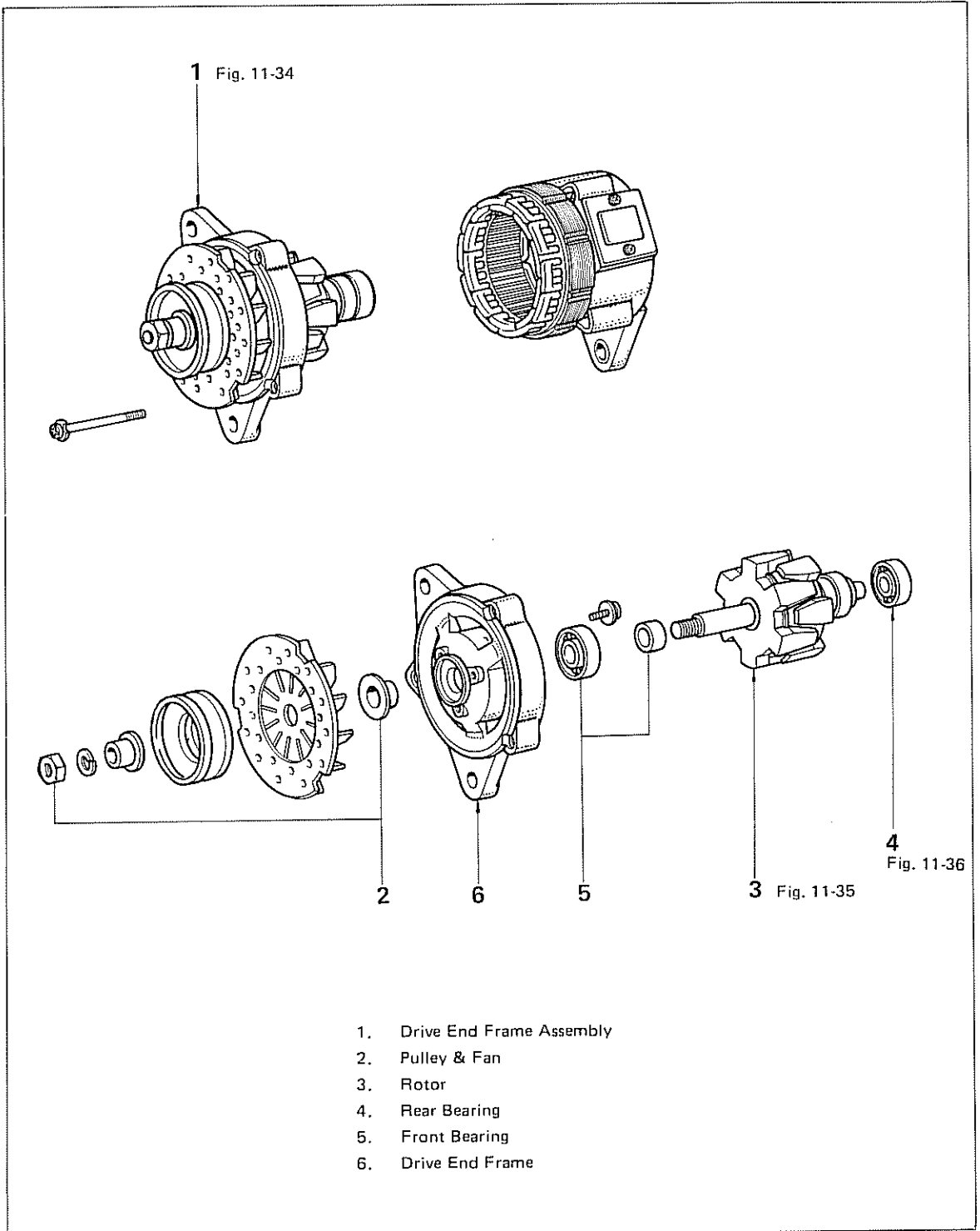

Disassemble the parts in the numerical order shown in the figure.

Fig. 11-33

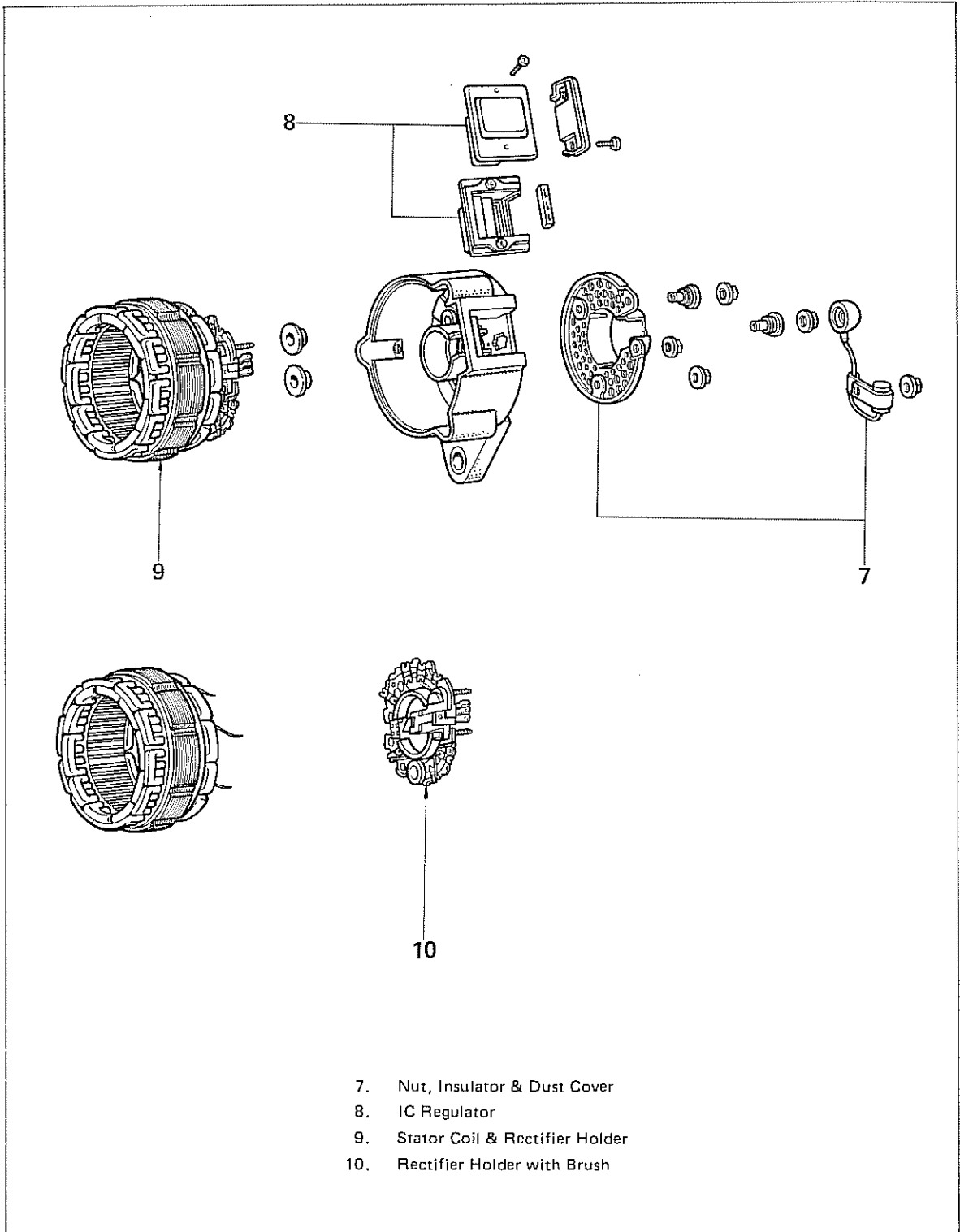

7. Nut, Insulator & Dust Cover
8. IC Regulator
9. Stator Coil & Rectifier Holder
10. Rectifier Holder with Brush

Fig. 11-34

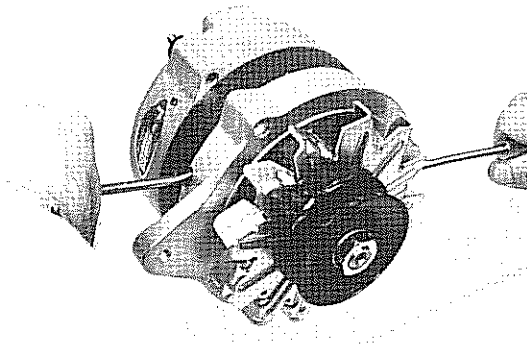

Pry the drive end frame from the stator and tap it off.

Fig. 11-35

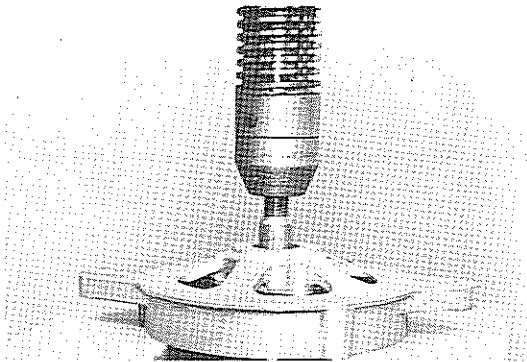

Remove the rotor from the drive end frame with a press.

Fig. 11-36

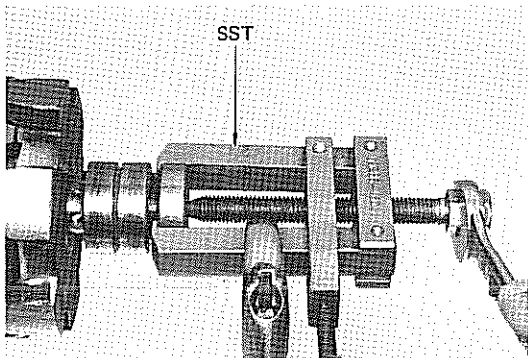

Remove the rotor shaft rear bearing with SST. SST [09286-46011]

Fig. 11-37

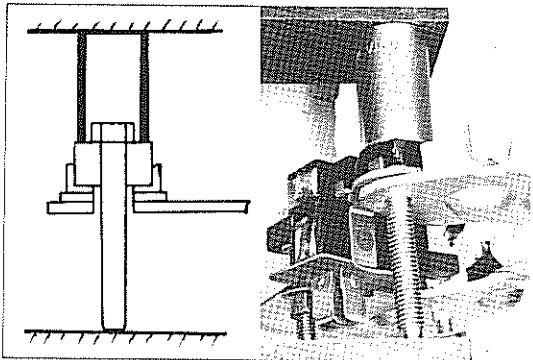

Remove the brush holder assembly with a 10 mm socket wrench and vise.

Fig. 11-38

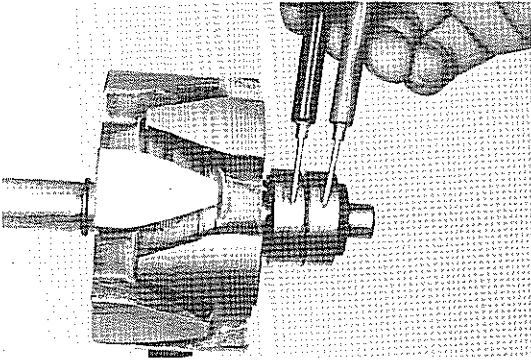

Fig. 11-39

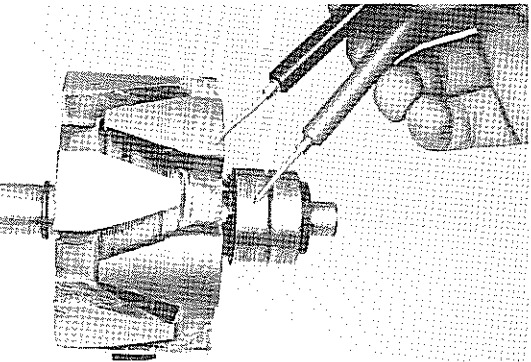

Fig. 11-40

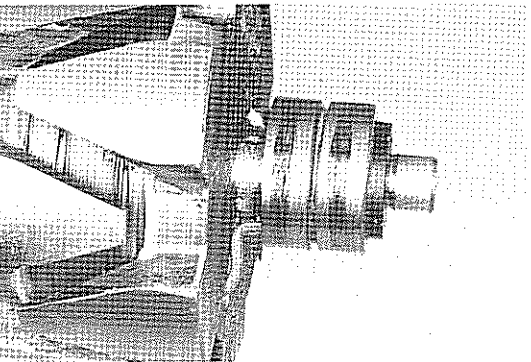
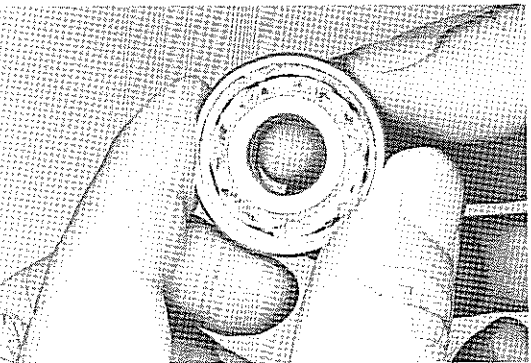

Fig. 11-41



INSPECTION & REPAIR

Rotor

1. Open circuit test

Standard resistance: 4.1 – 4.3 Ω



2. Ground test

Meter should indicate infinity.



3. Check slip ring for being dirt or burn.



Bearing

Check bearing for wear or roughness.

Fig. 11-42

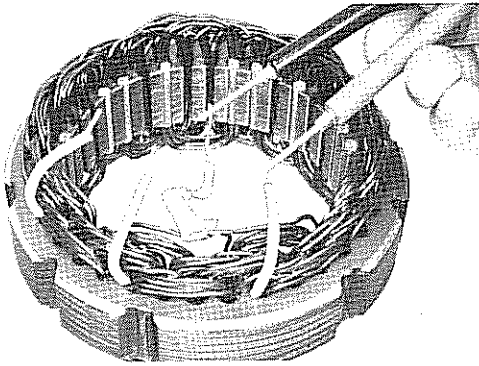

Stator

1. Open circuit test
Test all four leads for continuity.

Fig. 11-43

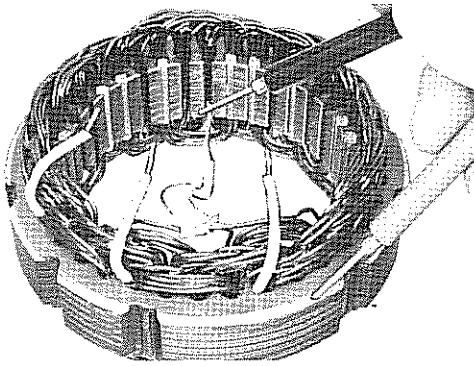

2. Ground test
Meter should indicate infinity.

Fig. 11-44

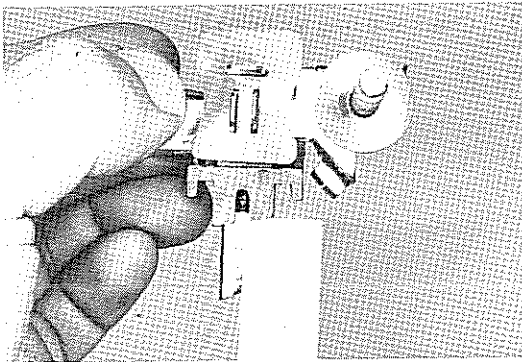

Brush & Brush Holder

1. Check the exposed brush length.
Minimum exposed length: 5.5 mm (0.22 in.)

Fig. 11-45

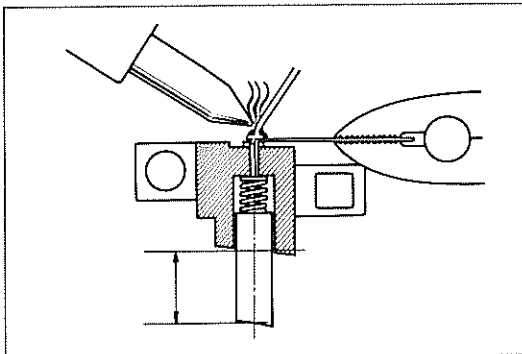

2. When replacing the brushes, assemble them as shown in the figure.

Exposed length: 12.5 mm (0.49 in.)

with IC regulator

16.5 mm (0.65 in.)

Fig. 11-46

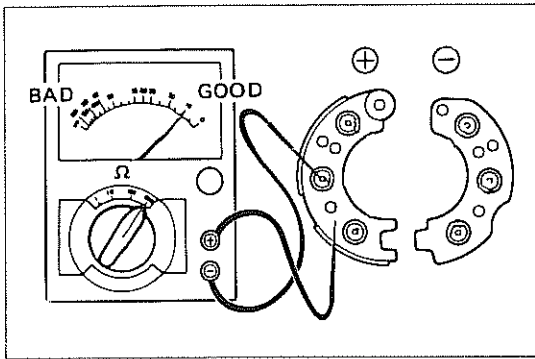
**Rectifier**

1. Rectifier holder positive side
Connect an ohmmeter (+) lead to the rectifier holder, and the (-) lead of the meter to the rectifier terminal. If there is no continuity, rectifier assembly must be replaced.

Fig. 11-47

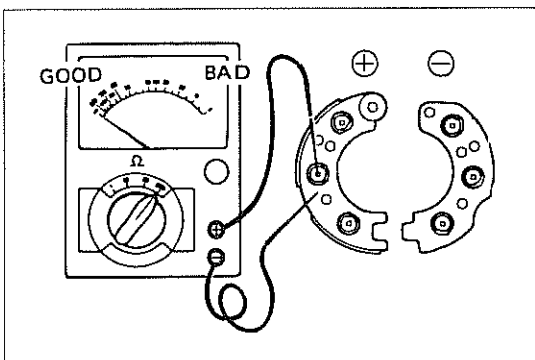

2. Reverse polarity of test leads and check again. If there is continuity, rectifier assembly must be replaced.

Fig. 11-48

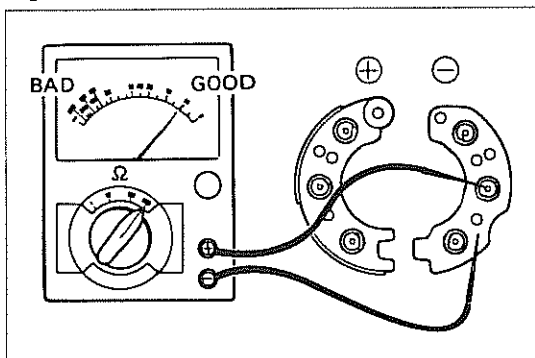

3. Rectifier holder negative side
Connect an ohmmeter (+) lead to the rectifier terminal, and the (-) lead of the meter to the rectifier holder. If there is no continuity, rectifier assembly must be replaced.

Fig. 11-49

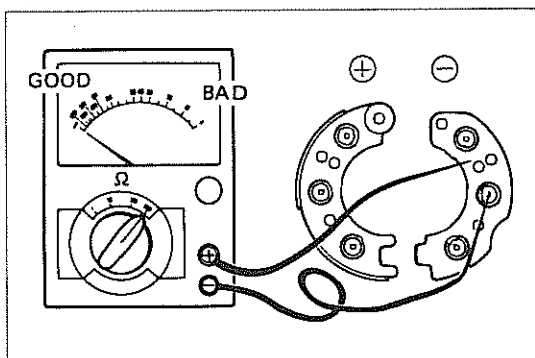

4. Reverse polarity of test leads and check again. If there is continuity, rectifier assembly must be replaced.

Fig. 11-50

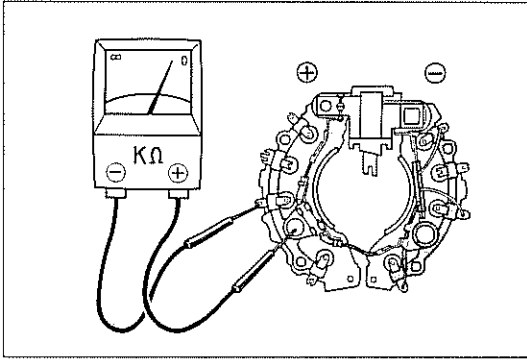

Rectifier (for Alternator with IC Regulator)

1. Rectifier holder positive side
Connect an ohmmeter (+) lead to the rectifier holder, and the (-) lead of the meter to the rectifier terminal. If there is no continuity, rectifier assembly must be replaced.

Fig. 11-51

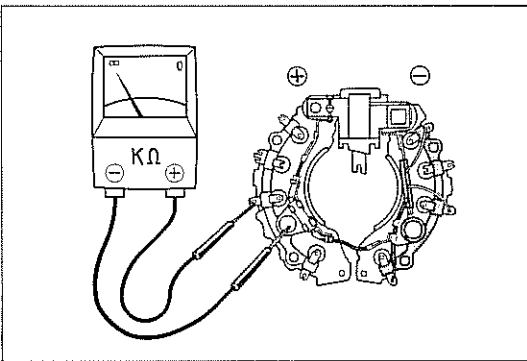

2. Reverse polarity of test leads and check again. If there is continuity, rectifier assembly must be replaced.

Fig. 11-52

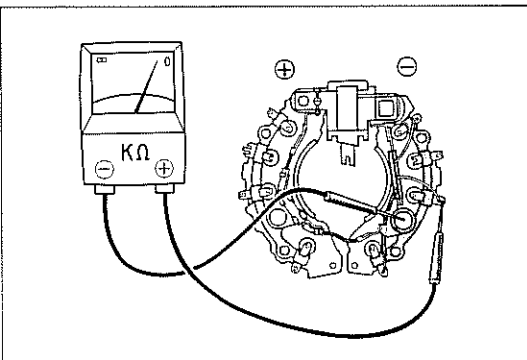

3. Rectifier holder negative side
Connect an ohmmeter (+) lead to the rectifier terminal, and the (-) lead of the meter to the rectifier holder. If there is non continuity, rectifier assembly must be replaced.

Fig. 11-53

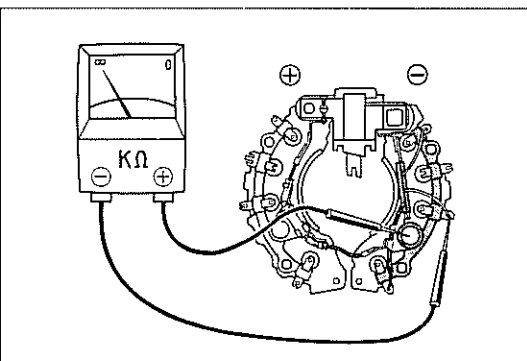

4. Reverse polarity of test leads and check again. If there is continuity, rectifier assembly must be replaced.

Fig. 11-54

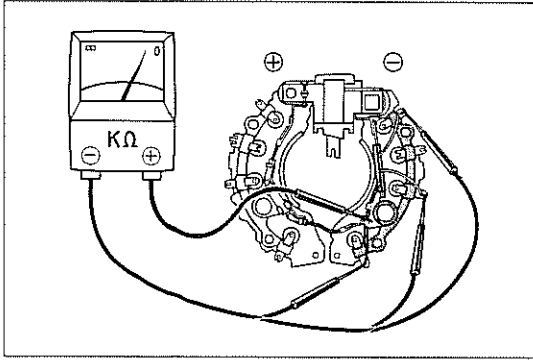

Field Diodes (for Alternator with IC Regulator)

1. Connect an ohmmeter (+) lead to the rectifier holder, and the (-) lead of the meter to the field diode terminal. If there is no continuity, rectifier assembly must be replaced.

Fig. 11-55

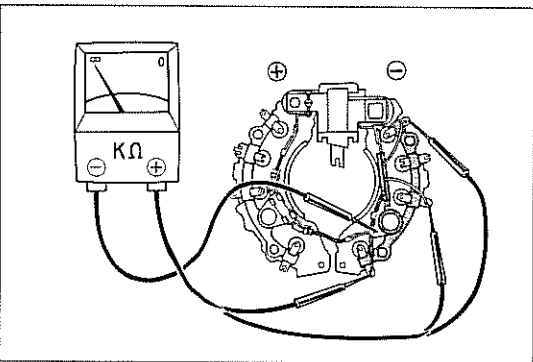

2. Reverse polarity of test leads and check again. If there is continuity, rectifier assembly must be replaced.

Fig. 11-56

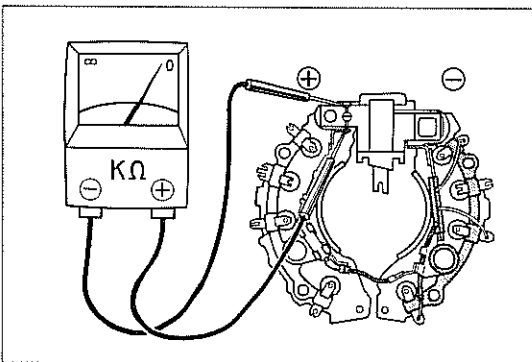

Diode (for Alternator with IC Regulator)

1. Connect an ohmmeter (+) lead to the resistor side, and the (-) lead of the meter to the diode other side. If there is no continuity, rectifier assembly must be replaced.

Fig. 11-57

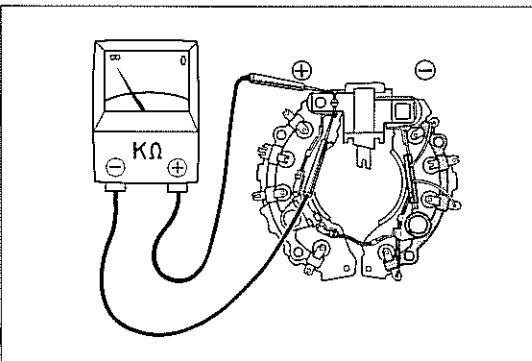

2. Reverse polarity of test leads and check again. If there is continuity, rectifier assembly must be replaced.

Fig. 11-58

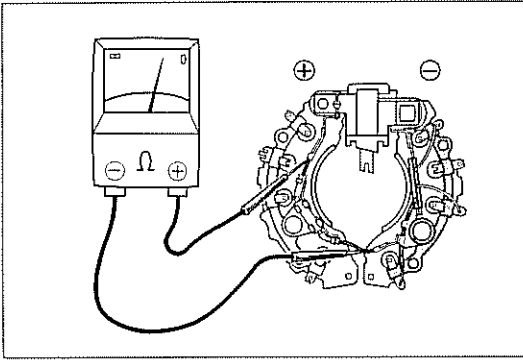
**Resistor (for Alternator with IC Regulator)**

Connect an ohmmeter (+) lead to the diode side, and the (-) lead of the meter to the (-) rectifier side. If there is no continuity, rectifier assembly must be replaced.

Resistance: 2.8 – 3.0 Ω

ASSEMBLY

Assemble the parts in the numerical order shown in the figure.

Fig. 11-59

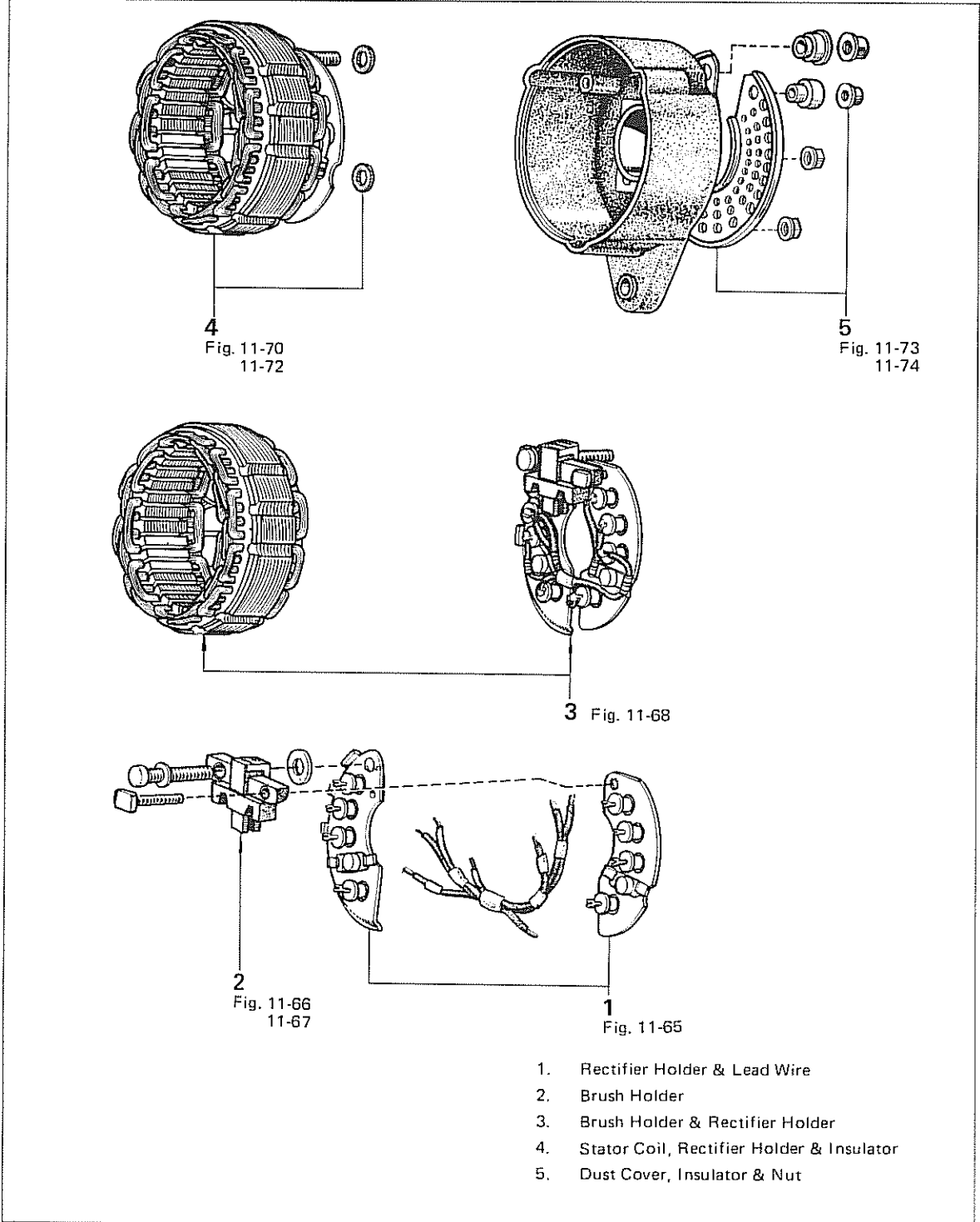

1. Rectifier Holder & Lead Wire
2. Brush Holder
3. Brush Holder & Rectifier Holder
4. Stator Coil, Rectifier Holder & Insulator
5. Dust Cover, Insulator & Nut

Assemble the parts in the numerical order shown in the figure.

Fig. 11-60

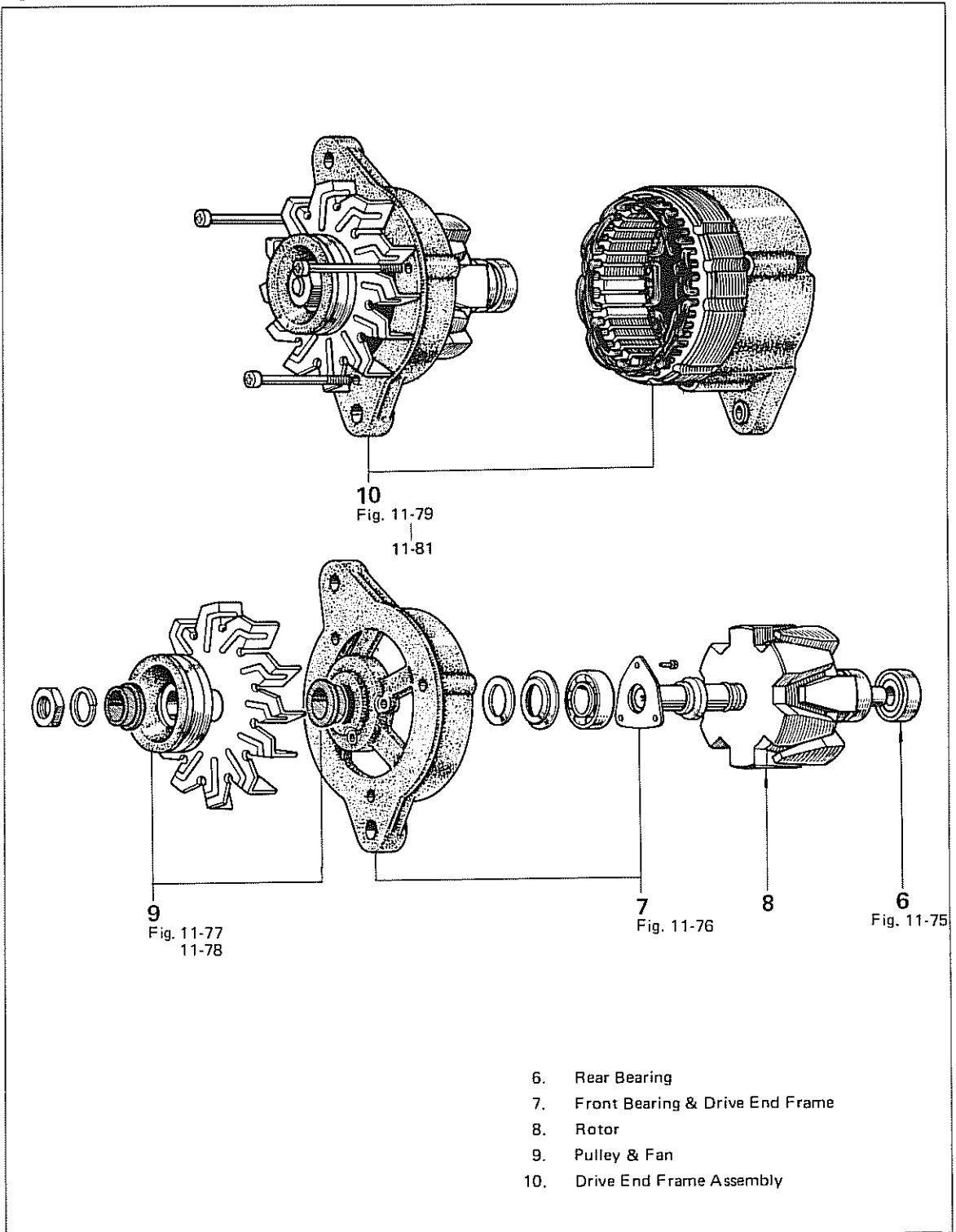

Assemble the parts in the numerical order shown in the figure.

Fig. 11-61

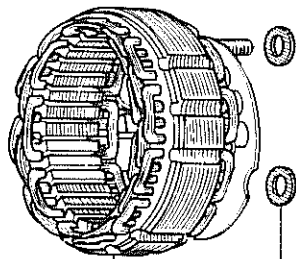

3
Fig. 11-72

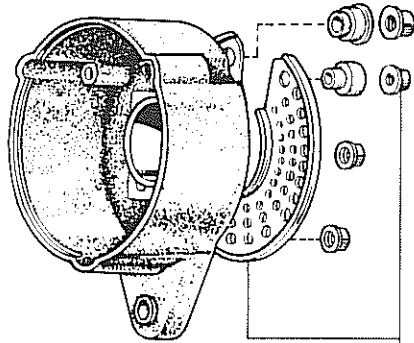

4
Fig. 11-73
11-74

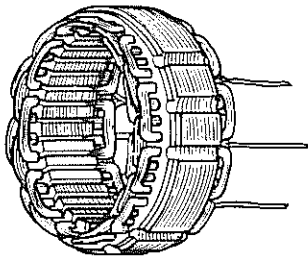

2
Fig. 11-69

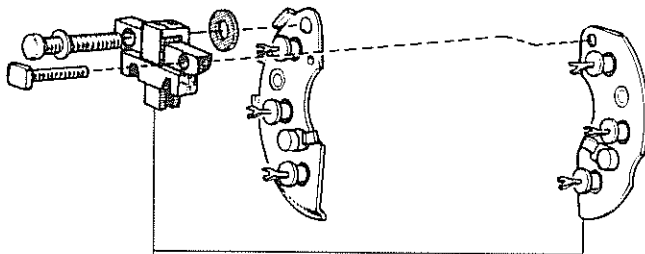

1
Fig. 11-66
11-67

1. Brush Holder & Rectifier
2. Brush Holder, Rectifier Holder & Stator Coil
3. Stator Coil, Rectifier Holder & Insulator
4. Dust Cover & Insulator

Assemble the parts in the numerical order shown in the figure.

Fig. 11-62

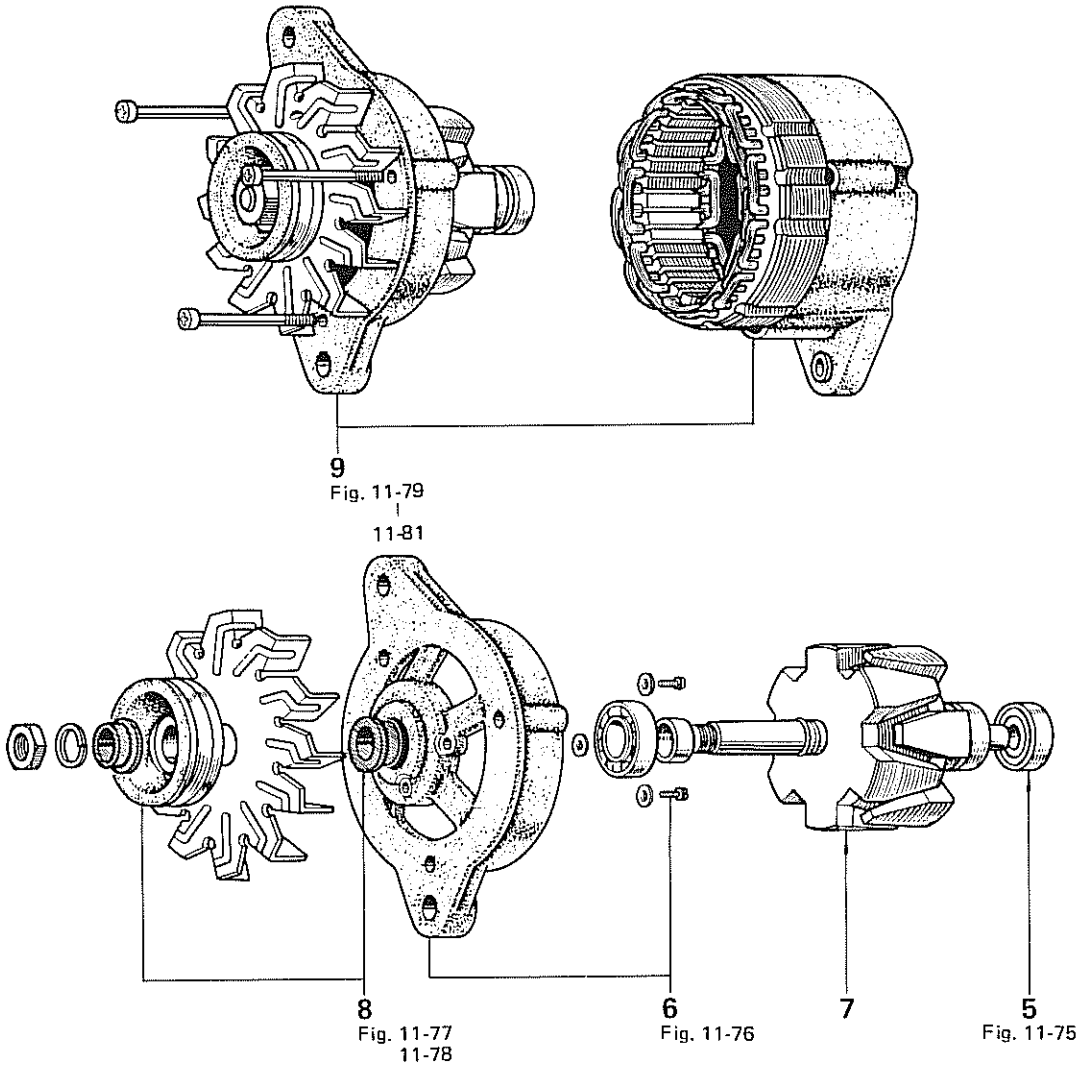

- 5. Rear Bearing
- 6. Front Bearing & Drive End Frame
- 7. Rotor
- 8. Pulley & Fan
- 9. Drive End Frame Assembly, Stator Coil & End Frame

For Alternator with IC Regulator

Assemble the parts in the numerical order shown in the figure.

Fig. 11-63

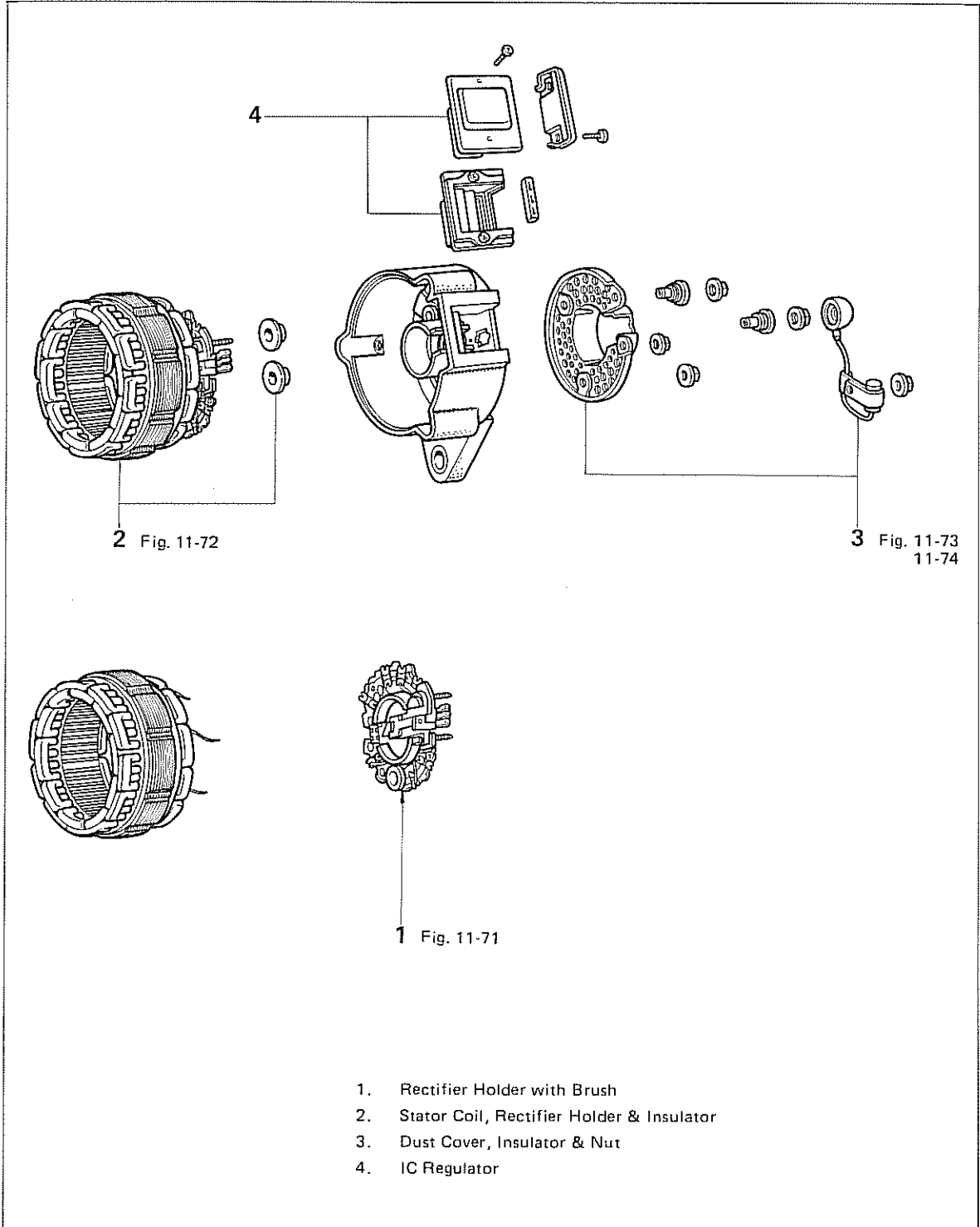

1. Rectifier Holder with Brush
2. Stator Coil, Rectifier Holder & Insulator
3. Dust Cover, Insulator & Nut
4. IC Regulator

Assemble the parts in the numerical order shown in the figure.

Fig. 11-64

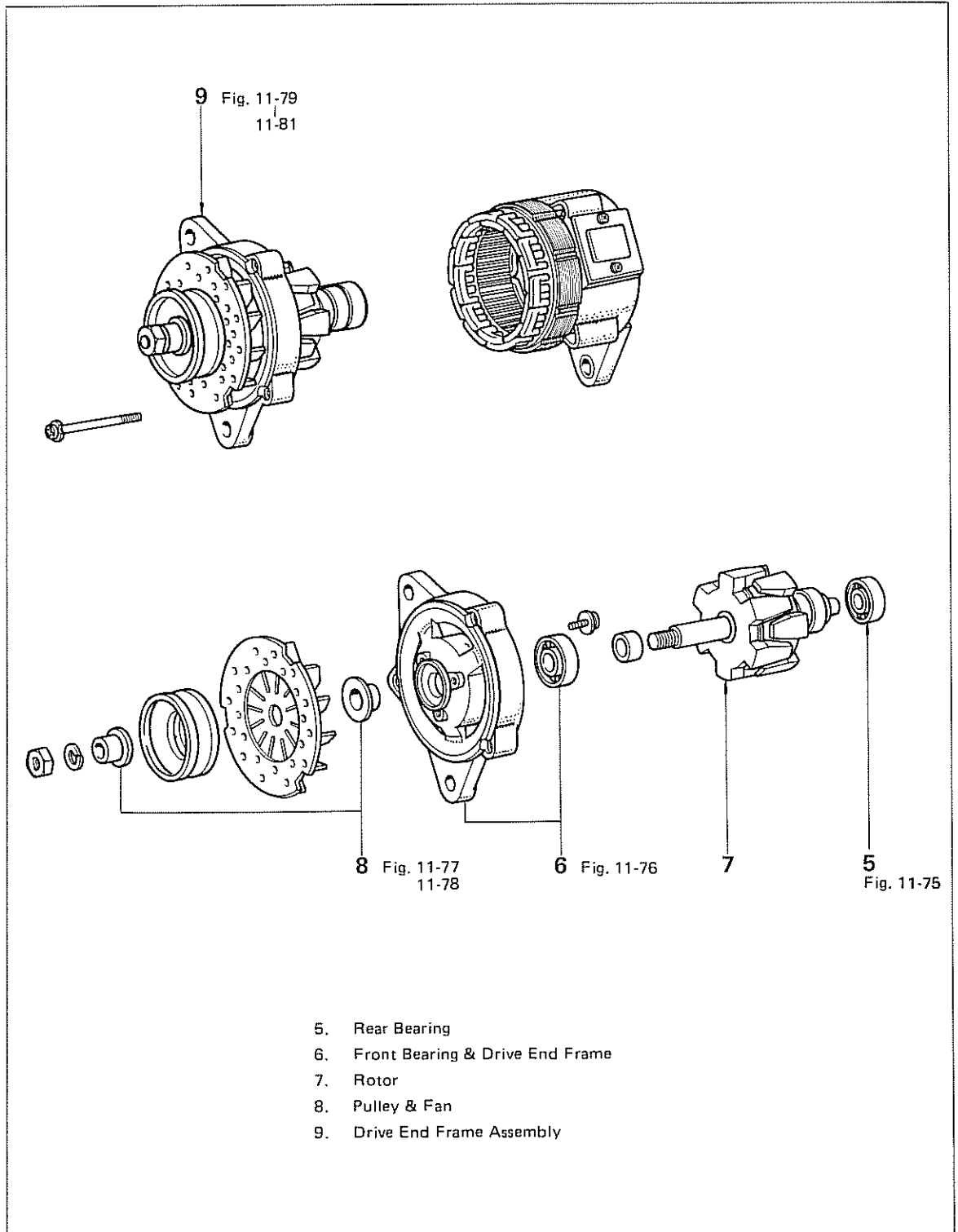
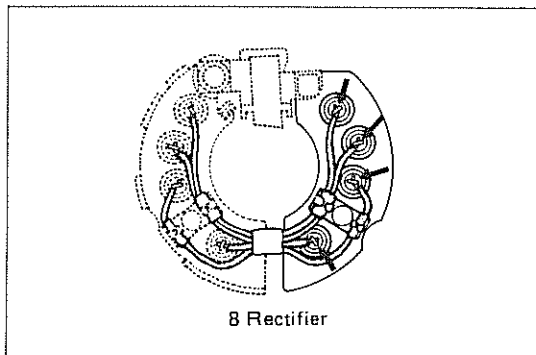
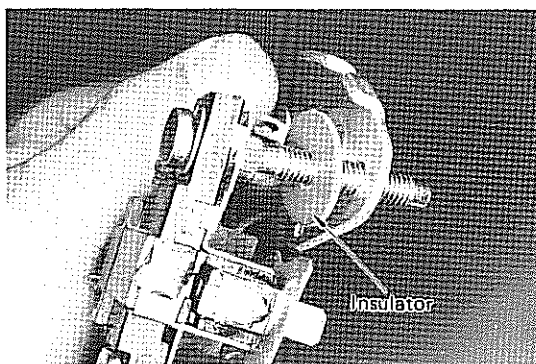

Fig. 11-65



[With 8 rectifier]
Solder negative side rectifiers.

Fig. 11-66



Insert insulator between the positive rectifier holder and brush holder.

Fig. 11-67

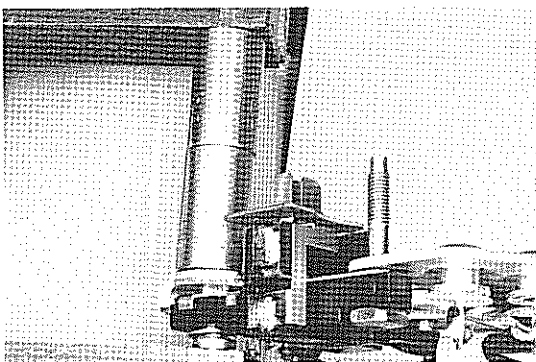

Install the brush holder onto the rectifier holder with a socket wrench and vise.

Fig. 11-68

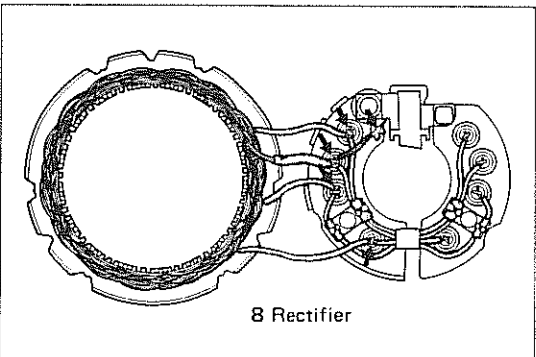

[With 8 rectifier]
Connect stator coil N lead onto (+) rectifier terminal and brush holder terminal.

Fig. 11-69

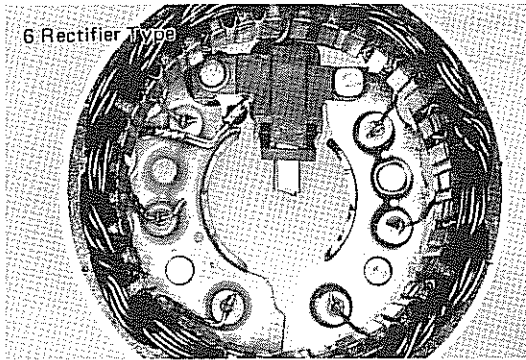

[With 6 rectifier]

Solder each lead wire onto rectifier or terminal as shown in the figure.

Fig. 11-70

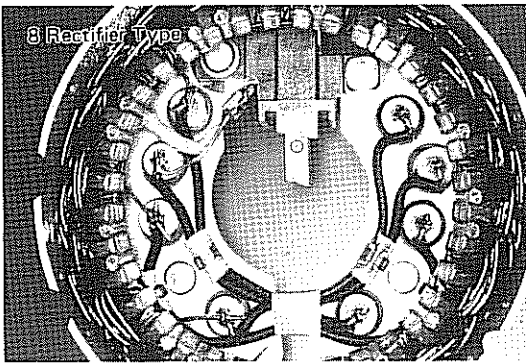

[With 8 rectifier]

Solder each lead wire onto rectifier or terminal as is shown in the figure.

Fig. 11-71

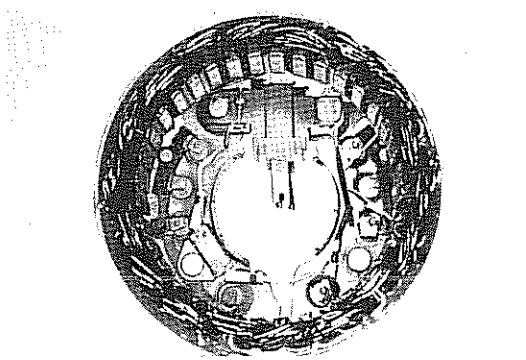

[with IC regulator]

Solder each lead wire onto rectifier or terminal as is shown in the figure.

Fig. 11-72

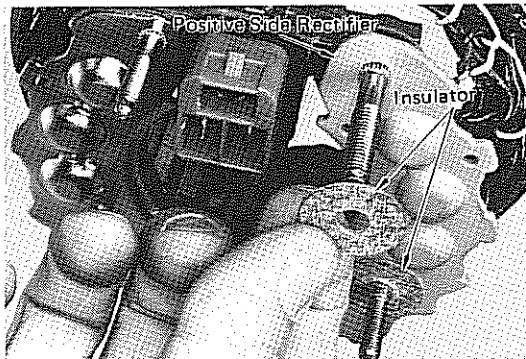

Assemble the rear end frame and rectifier holder with insulators.

Fig. 11-73

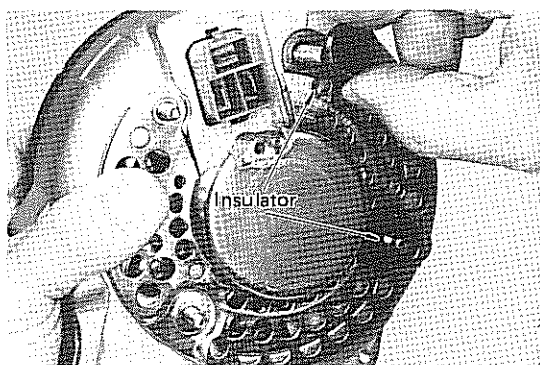

Assemble the rear end cover with the insulators.

Fig. 11-74

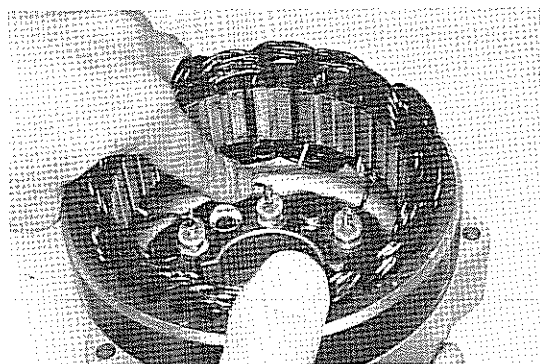

If there is danger of the stator coil terminal wiring contacting the frame or rotor, correct by bending the wiring.

Fig. 11-75

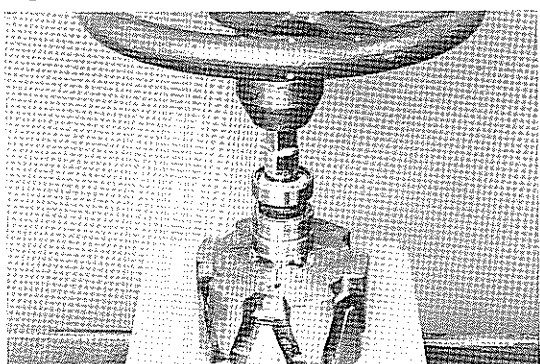

Press the rear bearing onto the rotor shaft, with a press.

Fig. 11-76

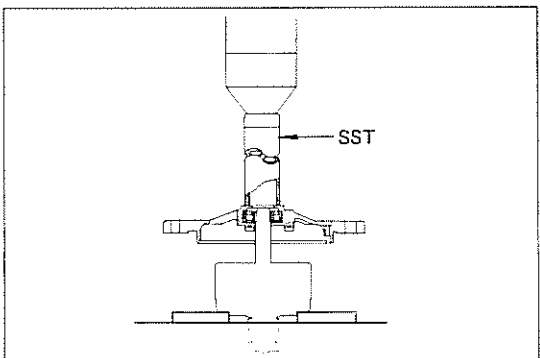

Press and drive the end frame assembly onto the rotor shaft with SST.
SST [09612-22010]

Fig. 11-77

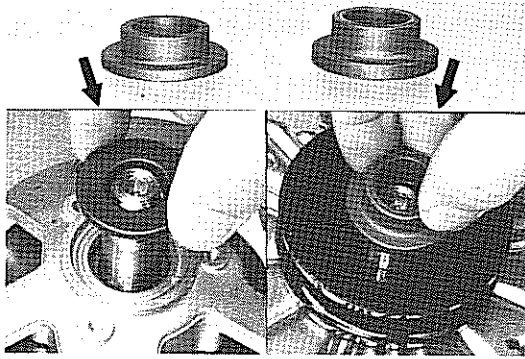

Install the collars as shown in the figure.

Fig. 11-78

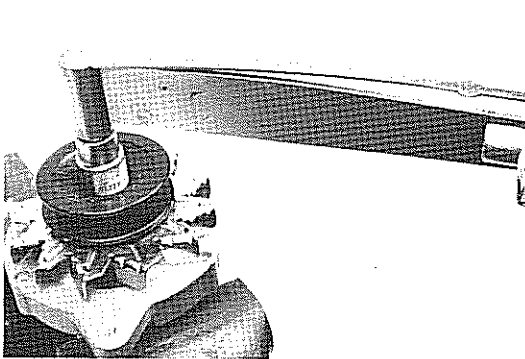

Tighten the nut to specified torque.

**Tightening torque: 5.0 – 6.5 kg-m
(37 – 47 ft-lb)**

Fig. 11-79

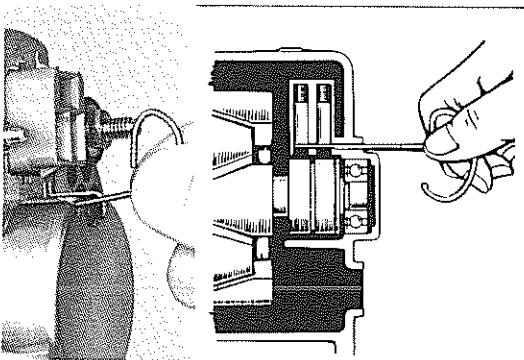

Push in brushes and temporarily lock them in place with a wire inserted through the access hole in end frame.

Position lead wires to clear rotor.

Fig. 11-80

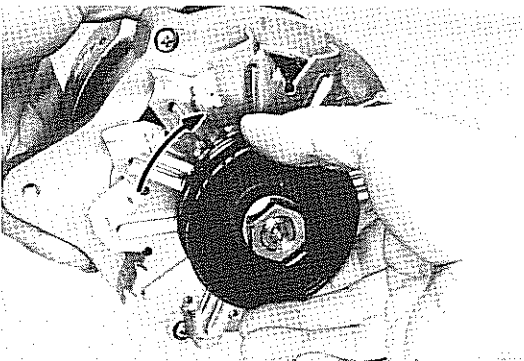

Remove locking wire from the rear end frame and make sure the rotor rotates smoothly.

Fig. 11-81

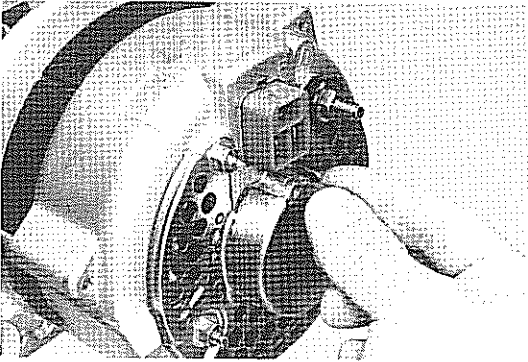

Seal the brush service hole.

ALTERNATOR REGULATOR

Fig. 11-82

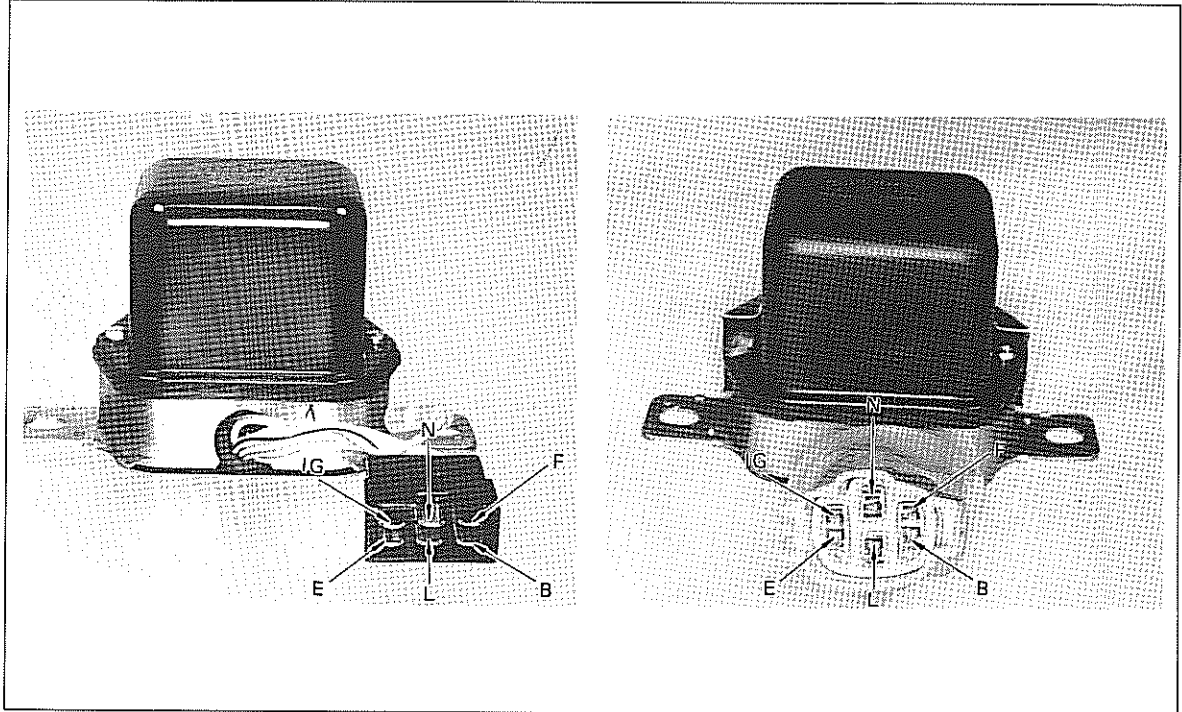
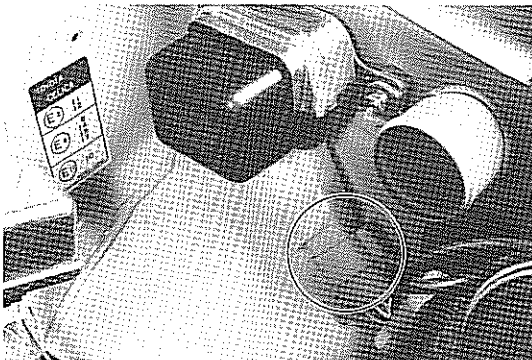

Fig. 11-83



INSPECTION & ADJUSTMENT

Check the connector fitting condition before inspecting the regulator.

Fig. 11-84

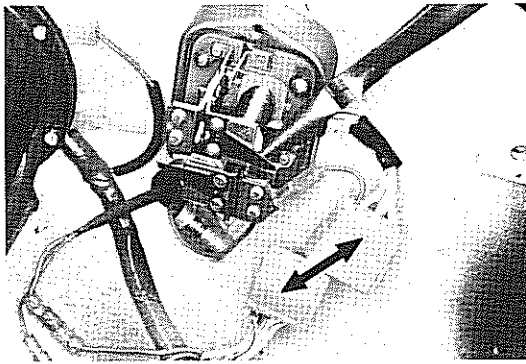

Always be sure to have the regulator connector pulled out when inspecting and adjusting.

Fig. 11-85

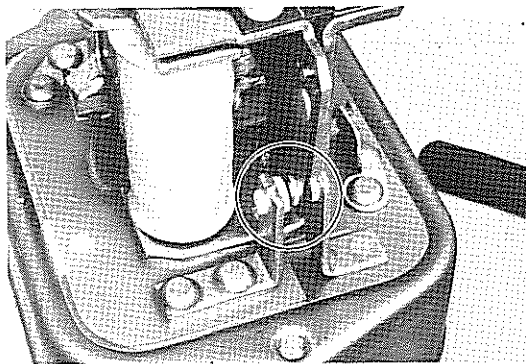

Inspect each point surface for burn or excessive damage. Replace if defective.

Fig. 11-86

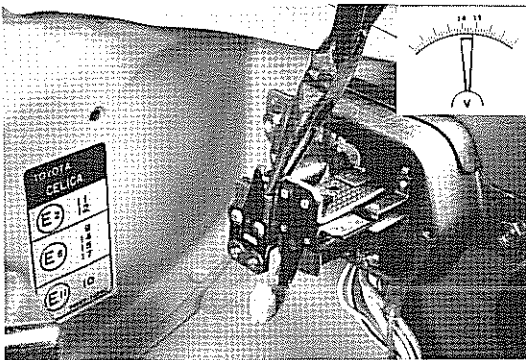

Voltage adjustment

To adjust, bend the voltage regulator adjusting arm.

Regulated voltage: 13.8 – 14.8V

Fig. 11-87

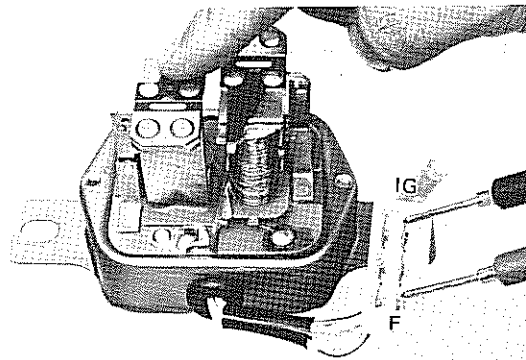

Resistance measurement between terminals.

IG – F

Voltage regulator	At rest	0 Ω
	Pulled in approx.	11 Ω

Fig. 11-88

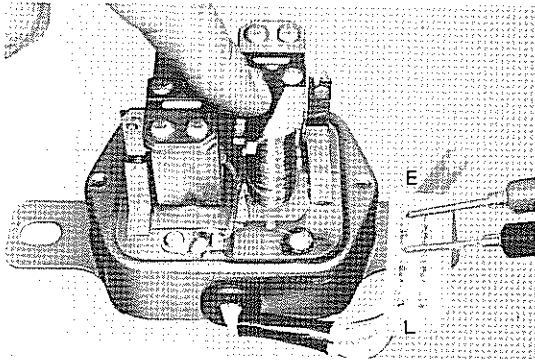

L – E

Voltage relay	At rest 0 Ω
	Pulled in approx. 100 Ω

Fig. 11-89

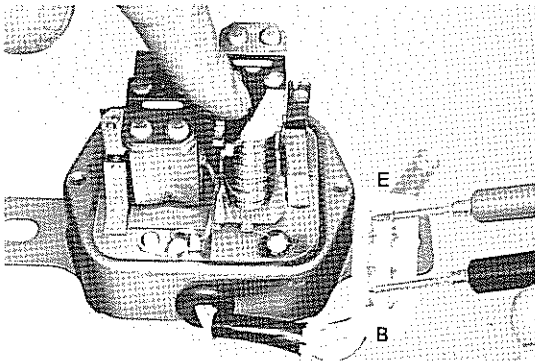

B – E

Voltage relay	At rest infinity
	Pulled in approx. 100 Ω

Fig. 11-90

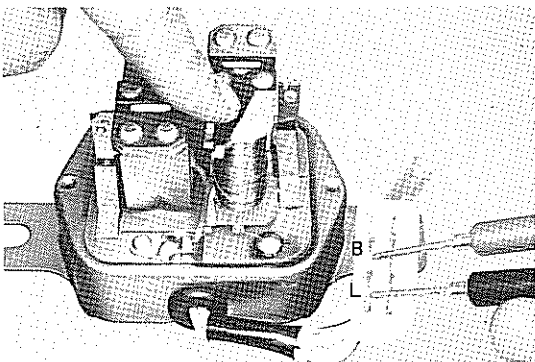

B – L

Voltage relay	At rest infinity
	Pulled in 0 Ω

Fig. 11-91

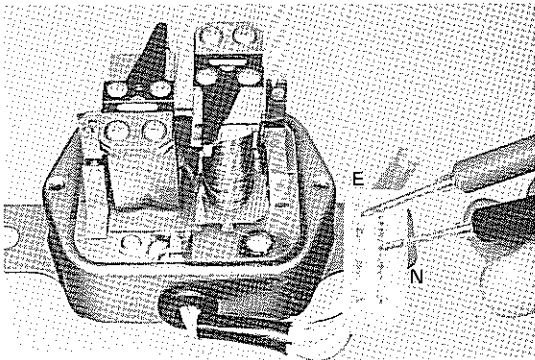

N – E

Approx. 25 Ω

MEMO
